



Owner's Manual

For professional use only

**Do not use this equipment
before reading this manual!**

PowerTwin 6900xLT DI



Model Number:

Gas Bare	448-350
Gas Complete	448-355
Gas Complete w/Heavy Duty Bypass Valve	448-360
230V Electric Bare	448-365
230V Electric Complete	448-370

NOTE: This manual contains important warnings and instructions. Please read and retain for reference.

Table of Contents

Safety Precautions	2
Grounding Instructions	3
Gasoline Engine Safety	4
Specifications	4
Introduction	5
Operation	5
Fueling	5
Operating the Swing Cart	6
Setup	6
Preparing to Paint	8
Painting	8
Pressure Relief Procedure	9
Cleanup	9
Cleaning a Clogged Tip	10
Maintenance	10
Daily Maintenance	10
Maintaining the Filter Assembly	11
Maintaining the Hydraulic System	11
Maintaining the Fluid Section	11
Basic Engine Maintenance (gas engine)	12
Replacing the Motor Brushes (electric motor)	12
Troubleshooting	13
Airless Gun	13
Fluid Section	13
Hydraulic Motor	14
Spray Patterns	15
Parts Lists and Service Instructions	20
Main Assembly	20
Cart Assembly	21
Belt Guard Assembly	21
Hydraulic Motor	22
Fluid Section	24
Hydraulic System	26
Gas Convertokit	27
DC— Electric Convertokit	27
Electric Convertokit, 230V	28
Bleed Valve Assembly	28
Filter Assembly	29
Heavy Duty Outlet Assembly (optional)	29
Heavy Duty Bleed Valve Assembly (optional)	29
Gun Manifold Assemblies (optional)	30
SAE O-Ring Fitting Installation	31
Accessories and Service Kits	31
Airless Tip Selection	31
Warranty	32

Safety Precautions

This manual contains information that must be read and understood before using the equipment. When you come to an area that has one of the following symbols, pay particular attention and make certain to heed the safeguard.



This symbol indicates a potential hazard that may cause serious injury or loss of life. Important safety information will follow.



This symbol indicates a potential hazard to you or to the equipment. Important information that tells how to prevent damage to the equipment or how to avoid causes of minor injuries will follow.

NOTE: Notes give important information that should be given special attention.



IMPORTANT SAFETY INSTRUCTIONS

A. SAVE THESE INSTRUCTIONS – To reduce the risks of fire or explosion, electrical shock, and the injury to persons, read and understand all instructions included in this manual. Be familiar with the controls and the proper usage of the equipment.

B. WARNING – To reduce the risk of fire or explosion:

1. Do not spray flammable or combustible materials near an open flame, pilot lights or sources of ignition such as hot objects, cigarettes, motors, electrical equipment and electrical appliances. Avoid creating sparks from connecting and disconnecting power cords.
2. For units intended for use with only water-based materials — Do not spray or clean with flammable liquids. For use with water-based liquids only.
3. For units intended for use with only water-based or mineral spirit-type materials with a minimum flash point of 21°C (69.8°F) — Do not spray or clean with liquids having a flash point of less than 21°C (69.8°F). Flash point is the temperature at which a fluid can produce enough vapor to ignite.
4. Paint or solvent flowing through the equipment is able to result in static electricity. Static electricity creates a risk of fire or explosion in the presence of paint or solvent fumes. All parts of the spray system, including the pump, hose assembly, spray gun and objects in and around the spray area shall be properly grounded to protect against static discharge and sparks. Use only conductive or grounded high-pressure airless paint sprayer hoses specified by the manufacturer.
5. Verify that all containers and collection systems are grounded to prevent static discharge.
6. Connect to a grounded outlet and use grounded extension cords. Do not use a 3 to 2 adapter.
7. Do not use a paint or solvent containing halogenated hydrocarbons. Such as chlorine, bleach, mildewcide, methylene chloride and trichloroethane. They are not compatible with aluminum. Contact the coating supplier about compatibility of material with aluminum.
8. Keep spray area well ventilated. Keep a good supply of fresh air moving through the area to keep the air within the spray area free from accumulation of flammable vapors. Keep pump assembly in well ventilated area. Do not spray pump assembly.
9. Do not smoke in the spray area.
10. Do not operate light switches, engines, or similar spark producing products in the spray area.
11. Keep area clean and free of paint or solvent containers, rags, and other flammable materials.
12. Know the contents of the paint and solvents being sprayed. Read all Material Safety Data Sheets (MSDS) and container labels provided with the paints and solvents. Follow the paint and solvent manufacture's safety instructions.
13. Place pump at least 25 feet (7.62 meters) from the spray object in a well ventilated area (add more hose if necessary). Flammable vapors are often heavier than air. Floor area must be extremely well ventilated. The pump contains arcing parts that emit sparks and can ignite vapors.
14. Plastic can cause static sparks. Never hang plastic to enclose spray area. Do not use plastic drop cloths when spraying flammable material.
15. Fire extinguisher equipment shall be present and working.

⚠ WARNING

C. WARNING – To reduce the risk of skin injection:

HAZARD:

Injection injury – A high pressure fluid stream produced by this equipment can pierce the skin and underlying tissues, leading to a serious injury and possible amputation. See a physician immediately. DO NOT TREAT AN INJECTION AS A SIMPLE CUT.

1. Do not aim the gun at, or spray any person or animal.
2. Keep hands and other body parts away from the discharge. For example, do not try to stop leaks with any part of the body.
3. Always use the nozzle tip guard. Do not spray without the nozzle tip guard in place.
4. Only use a nozzle tip specified by the manufacturer.
5. Use caution when cleaning and changing nozzle tips. In the case where the nozzle tip clogs while spraying, ALWAYS lock gun trigger, shut pump off, and release all pressure before servicing, cleaning tip or guard, or changing tip. Pressure will not be released by turning off the motor. The PRIME/SPRAY valve handle must be turned to PRIME to relieve the pressure. Refer to PRESSURE RELIEF PROCEDURE described in the pump manual.
6. Do not leave the unit energized or under pressure while unattended. When the unit is not in use, turn off the unit and relieve the pressure in accordance with the manufacturer's instructions.
7. High-pressure spray is able to inject toxins into the body and cause serious bodily injury. In the event that injection occurs, seek medical attention immediately.
8. Check hoses and parts for signs of damage, a leak can inject material into the skin. Inspect hose before each use. Replace any damaged hoses or parts.
9. This system is capable of producing 3300 PSI / 22.8 MPa. Only use replacement parts or accessories that are specified by the manufacturer and that are rated a minimum of 3300 PSI. This includes spray tips, nozzle guards, guns, extensions, fittings, and hose.
10. Always engage the trigger lock when not spraying. Verify the trigger lock is functioning properly.
11. Verify that all connections are secure before operating the unit.
12. Know how to stop the unit and bleed pressure quickly. Be thoroughly familiar with the controls. Pressure will not be released by turning off the motor. The PRIME/SPRAY valve handle must be turned to PRIME to relieve the pressure. Refer to PRESSURE RELIEF PROCEDURE described in the pump manual.
13. Always remove the spray tip before flushing or cleaning the system.

⚠ WARNING

D. WARNING – To reduce the risk of injury:

1. Always wear appropriate gloves, eye protection, clothing and a respirator or mask when painting. Hazardous vapors – Paints, solvents, insecticides, and other materials can be harmful if inhaled or come in contact with body. Vapors can cause severe nausea, fainting or poisoning.
2. Do not operate or spray near children. Keep children away from equipment at all times.
3. Do not overreach or stand on an unstable support. Keep effective footing and balance at all times.
4. Stay alert and watch what you are doing.
5. Do not operate the unit when fatigued or under the influence of drugs or alcohol.

6. Do not kink or over-bend the hose. Airless hose can develop leaks from wear, kinking and abuse. A leak can inject material into the skin.
7. Do not expose the hose to temperatures or pressures in excess of those specified by manufacturer.
8. Do not use the hose as a strength member to pull or lift the equipment.
9. Use lowest possible pressure to flush equipment.
10. Follow all appropriate local, state and national codes governing ventilation, fire prevention and operation.
11. The United States Government Safety Standards have been adopted under the Occupational Safety and Health Act (OSHA). These standards, particularly part 1910 of the General Standards and part 1926 of the Construction Standards should be consulted.
12. Before each use, check all hoses for cuts, leaks, abrasion or bulging of cover. Check for damage or movement of couplings. Immediately replace hose if any of those conditions exist. Never repair a paint hose. Replace with a conductive high-pressure hose.
13. Do not spray outdoors on windy days.
14. Always unplug cord from outlet before working on equipment.

Grounding Instructions

Electric models must be grounded. In the event of an electrical short circuit, grounding reduces the risk of electric shock by providing an escape wire for the electric current. This product is equipped with a cord having a grounding wire with an appropriate grounding plug. The plug must be plugged into an outlet that is properly installed and grounded in accordance with all local codes and ordinances.

DANGER — Improper installation of the grounding plug can result in a risk of electric shock. If repair or replacement of the cord or plug is necessary, do not connect the green grounding wire to either flat blade terminal. The wire with insulation having a green outer surface with or without yellow stripes is the grounding wire and must be connected to the grounding pin.

Check with a qualified electrician or serviceman if the grounding instructions are not completely understood, or if you are in doubt as to whether the product is properly grounded. Do not modify the plug provided. If the plug will not fit the outlet, have the proper outlet installed by a qualified electrician.

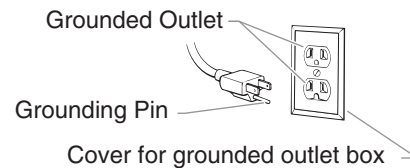

⚠ CAUTION

Use only a 3-wire extension cord that has a 3-blade grounding plug and a 3-slot receptacle that will accept the plug on the product. Make sure your extension cord is in good condition. When using an extension cord, be sure to use one heavy enough to carry the current your product will draw. An undersized cord will cause a drop in line voltage resulting in loss of power and overheating. A 12 gauge cord is recommended. If an extension cord is to be used outdoors, it must be marked with the suffix W-A after the cord type designation. For example, a designation of SJTW-A would indicate that the cord would be appropriate for outdoor use.

Gasoline Engine Safety



The engine exhaust from this sprayer contains chemicals known to the State of California to cause cancer, birth defects, or other reproductive harm.

1. Honda engines are designed to give safe and dependable service if operated according to instructions. Read and understand the Honda Owner's Manual before operating the engine. Failure to do so could result in personal injury or equipment damage.
2. To prevent fire hazards and to provide adequate ventilation, keep the engine at least 1 meter (3 feet) away from buildings and other equipment during operation. Do not place flammable objects close to the engine.
3. Children and pets must be kept away from the area of operation due to a possibility of burns from hot engine components or injury from any equipment the engine may be used to operate.
4. Know how to stop the engine quickly, and understand the operation of all controls. Never permit anyone to operate the engine without proper instructions.
5. Gasoline is extremely flammable and is explosive under certain conditions.
6. Refuel in a well-ventilated area with the engine stopped. Do not smoke or allow flames or sparks in the refueling area or where gasoline is stored.
7. Do not overfill the fuel tank. After refueling, make sure the tank cap is closed properly and securely.
8. Be careful not to spill fuel when refueling. Fuel vapor or spilled fuel may ignite. If any fuel is spilled, make sure the area is dry before starting the engine.
9. Never run the engine in an enclosed or confined area. Exhaust contains poisonous carbon monoxide gas; exposure may cause loss of consciousness and may lead to death.
10. The muffler becomes very hot during operation and remains hot for a while after stopping the engine. Be careful not to touch the muffler while it is hot. To avoid severe burns or fire hazards, let the engine cool before transporting it or storing it indoors.
11. Never ship/transport sprayer with gasoline in the tank.



DO NOT use this equipment to spray water or acid.



Do not lift by cart handle when loading or unloading.

Specifications

Gas Sprayer

Gallons per minute (GPM)	2.15 (8.14 LPM)
Cycle rate per gallon.....	51 (14.5 cycles/liter)
Maximum tip sizes	1 gun = .048"
	2 guns = .033"
	3 guns = .023"
	4 guns = .019"
Maximum pressure	3300 PSI (22.8 MPa)
Power	Honda 5.5 HP, 4-stroke, single cylinder, overhead valve engine w/oil alert
Fuel capacity.....	0.97 US gallons (approx. 3.5 hours run time)
Halogenated solvent compatible.....	Yes
Weight.....	149 lbs. (67.6 kg.)
Inlet paint filter	10 mesh "Rock Catcher"
Outlet paint filter.....	50 mesh, 18 in. ²
Pump inlet.....	1" NPT(F)
Pump outlet.....	1/2" NPT(F) to paint filter
Paint filter hose connections.....	3/8" NPS(M)
	3/8" NPT(F) (plugged)
	1/4" NPT (plugged)
Dimensions	43" L (109 cm) x
	26" W (66 cm) x
	35" H (89 cm)

Fluid section wetted parts:

Electroless nickel plated ductile iron, electroless nickel plated carbon steel, stainless steel, tungsten carbide, Teflon, thiokol impregnated leather, ultra high molecular weight polyethylene.

Electric Sprayer

Gallons per minute (GPM)	1.25 (4.7 LPM)
Cycle rate per gallon.....	55 (14.5 cycles/liter)
Maximum tip sizes	1 gun = .036"
	2 guns = .026"
	3 guns = .019"
Maximum pressure	3300 psi (22.8 MPa)
Power	2 HP DC Motor, 115V 15.5A, overload protected
Halogenated solvent compatible.....	Yes
Weight.....	165 lbs. (74.8 kg.)
Inlet paint filter	10 mesh "Rock Catcher"
Outlet paint filter.....	50 mesh, 18 in. ²
Pump inlet.....	1" NPT(F)
Pump outlet.....	1/2" NPT(F) to paint filter
Paint filter hose connections.....	3/8" NPS(M)
	3/8" NPT(F) (plugged)
	1/4" NPT (plugged)
Dimensions	43" L (109 cm) x
	26" W (66 cm) x
	35" H (89 cm)

Fluid section wetted parts:

Electroless nickel plated ductile iron, electroless nickel plated carbon steel, stainless steel, tungsten carbide, Teflon, thiokol impregnated leather, ultra high molecular weight polyethylene.

Introduction

Congratulations on having selected the finest airless sprayer available in the world. Speeflo piston pumps are tireless workhorses — so tough they are virtually indestructible, even under the most severe service. Speeflo designs and builds equipment with superior quality and reliability. Equipment that will last for years with minimal maintenance and downtime. This equipment will make you money year after year. We thank you for your purchase and welcome you to our large and growing family of Speeflo users.

The unique ability of this PowrTwin to operate with either gas or electric power provides you with the flexibility to work indoors or outside where no electricity is available.

Hydraulic drive makes possible the longest stroke and slowest cycling pumps in the industry, which translates into low maintenance and longer life. Electric sprayers operate quietly with no motor starting and stopping.

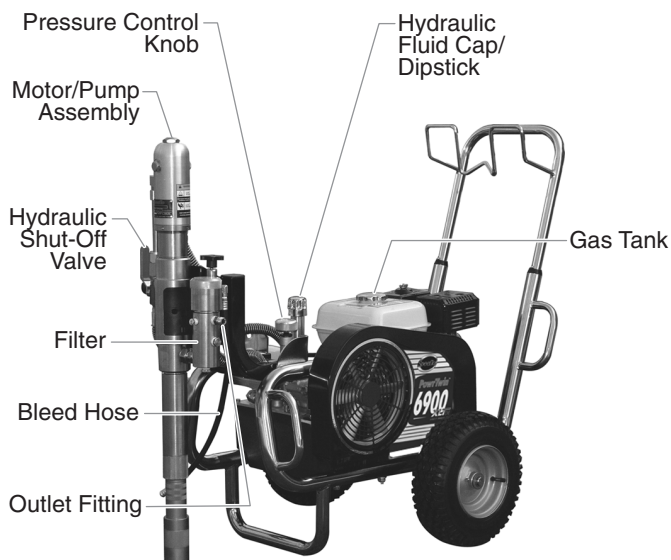

This PowrTwin is equipped with Speeflo's exclusive fluid pump. This technology will give you significantly longer rod, cylinder, and packing life than any other sprayer built in the world. This double ball piston pump employs a dependable and durable time-tested design. All pumps use thick, stainless steel rod and cylinder parts. Highly polished parts reduce friction, extend packing life, and avoid damage from corrosion and abrasion. More than 100,000 of these pumps are in operation around the world.

This PowrTwin offers other cost saving features:

- Freeze-proof pressure control
- Choice of power — gas, electric, or both
- Tungsten carbide reversible valve seats
- Self-adjusting packings
- Exclusive hand-tight swivel foot valve
- Large capacity inline paint filter
- Waterborne compatible
- "Floating Ball" pressure bleed valve

You have made an excellent choice. We know you will be pleased with your new PowrTwin. Thanks again for selecting Speeflo. We appreciate your business.

Operation

Fueling (gas engine)



Gasoline is extremely flammable and is explosive under certain conditions.

- ALWAYS turn the engine off before refueling.
- Refuel in a well-ventilated area.
- Do not smoke or allow flames or sparks in the refueling area or where gasoline is stored.
- Do not overfill the fuel tank. After refueling, make sure the tank cap is closed properly and securely.
- Be careful not to spill fuel when refueling. Spilled fuel or fuel vapor may ignite. If any fuel is spilled, make sure the area is dry before starting the engine.
- Avoid repeated or prolonged contact with skin or breathing of vapor.
- Keep out of the reach of children.

Fuel Specifications

- Use automotive gasoline that has a pump octane number of 86 or higher, or that has a research octane number of 91 or higher. Use of a lower octane gasoline can cause persistent "pinging" or heavy "spark knock" (a metallic rapping noise) which, if severe, can lead to engine damage.

NOTE: If "spark knock" or "pinging" occurs at a steady engine speed under normal load, change brands of gasoline. If spark knock or pinging persists, consult an authorized dealer of the engine manufacturer. Failure to do so is considered misuse, and damage caused by misuse is not covered by the engine manufacturer's limited warranty.

Occasionally you may experience light spark knock while operating under heavy loads. This is no cause for concern, it simply means your engine is operating efficiently.

- Unleaded fuel produces fewer engine and spark plug deposits and extends the life of the exhaust system components.
- Never use stale or contaminated gasoline or an oil/gasoline mixture. Avoid getting dirt, dust, or water in the fuel tank.

Gasolines Containing Alcohol

If you decide to use a gasoline containing alcohol (gasohol), be sure its octane rating is at least as high as that recommended by the engine manufacturer. There are two types of "gasohol": one containing ethanol, and the other containing methanol. Do not use gasohol that contains more than 10% ethanol. Do not use gasoline containing methanol (methyl or wood alcohol) that does not also contain co-solvents and corrosion inhibitors for methanol. Never use gasoline containing more than 5% methanol, even if it has co-solvents and corrosion inhibitors.

NOTE: Fuel system damage or engine performance problems resulting from the use of fuels that contain alcohol is not covered under the warranty. The engine manufacturer cannot endorse the use of fuels containing methanol since evidence of their suitability is incomplete at this time.

Before buying gasoline from an unfamiliar station, try to find out if the gasoline contains alcohol. If it does, confirm the type and percentage of alcohol used. If you notice any undesirable operating characteristics while using a gasoline that contains alcohol, or one that you think contains alcohol, switch to a gasoline that you know does not contain alcohol.

Operating the Swing Cart

⚠ WARNING

Use caution when operating the swing cart. Keep fingers and feet clear of moving parts.

The swing cart allows the motor/pump assembly to be rotated between two positions.

Position #1: Working Position

The vertical position of the motor/pump assembly is the working position. This position allows complete submersion of the siphon tube on the fluid section into a paint bucket. The maximum height paint bucket that can be used is 28 1/8" (71.4 cm).



Position #2: Transporting Position

The horizontal position of the motor/pump assembly is the transporting position. This position allows easy removal of the paint bucket and a sprayer height of 30" (76.2 cm) for ease of transportation.



Use the following procedure to change the position of the motor/pump assembly.

1. Holding the handle grip with one hand, pull the locking pin out of the locking hole on the cart with the other hand. This allows the motor/pump assembly mounted on the swing cart frame to move from one position to the other.
2. Let go of the locking pin once it is free of the locking hole.
3. Move the motor/pump assembly to the desired position. The locking pin is spring loaded and will automatically engage the locking hole on the swing cart at the new position.

Setup

⚠ WARNING

Read, understand, and follow all warnings before starting or operating this sprayer.

1. Make sure the bleed hose is threaded into the bleed valve. It has factory installed Teflon tape on the fitting and should be tightened wrench tight.

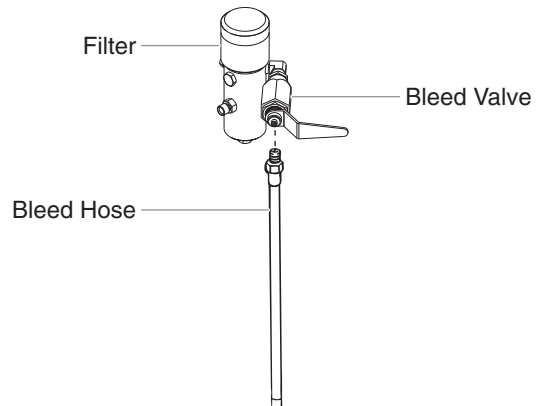

2. Attach a minimum of 50' of nylon airless spray hose to the sprayer. Do not use Teflon tape or thread sealant on the spray hose connection.
3. Attach an airless spray gun to the spray hose. Do not attach the tip to the spray gun yet. Remove the tip if it is already attached.
 - a. To use two guns, remove the plug from the second gun outlet on the filter assembly. Connect a hose and gun to the outlet.

NOTE: The gas sprayer is engineered to handle up to 4 guns with .019" tips and the electric sprayer is engineered to handle up to 3 guns with .019" tips. For multiple gun operation, connect a multiple gun manifold to the single gun outlet. Connect a hose and gun to each outlet. Make sure the second gun outlet remains plugged.

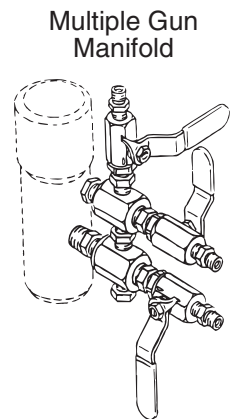

4. Fill the oil cup 1/2 full with Speeflo Piston Lube (P/N 314-480) supplied by the factory. This extends packing life.
5. Check the hydraulic fluid level daily before starting the sprayer. The hydraulic fluid level should be at the "Full" mark on the dipstick. Refer to the Maintenance section of this manual for hydraulic system maintenance instructions.

⚠ CAUTION

Use of Speeflo's Coolflo™ Hydraulic Fluid (P/N 430-361) is mandatory in the hydraulic system. Do not use any other hydraulic fluid. Use of any other hydraulic fluid may seriously damage the hydraulic system and will void the warranty.

6. For gas models, check the engine oil level daily before starting the sprayer. The gasoline engine oil level is determined by the engine manufacturer. Refer to the engine manufacturer's service manual supplied with this sprayer.
7. For electric models, use a 20 amp service outlet. Always locate the electric model within 10 to 15 feet of the service outlet. Use a short electric cable and a long paint hose. Any extension cord will create some voltage drop. If an extension cord is necessary, use only a grounded 3-wire #12 gauge extension cord.

NOTE: If the sprayer is being operated in an area that is overloaded by other appliances or low voltage conditions, it is important to start the sprayer "unloaded." Tip the electric motor forward so that the belt is loosened and the motor starts without full load. This reduces the amperage draw on starting and may avoid tripping the circuit breaker.

8. Make sure the sprayer is grounded. All sprayers are equipped with a grounding lug. A grounding cable (not supplied) should be used to connect the sprayer to a true earth ground. Check your local electrical regulations for detailed grounding instructions. See the Accessories and Service Kits section near the back of this manual for grounding cable ordering information.

⚠ WARNING

Proper grounding is important. This applies to both gas and electric powered models. The passage of some materials through the nylon fluid hose will build up a static electric charge, which if discharged, could ignite solvent vapors present and create an explosion.

9. Strain all paints with a nylon strainer to ensure trouble free operation and freedom from frequent cleaning of the inlet screen and gun filter.
10. Make sure the spray area is well ventilated to prevent hazardous operation with volatile solvents or exhaust fumes.

⚠ WARNING

If lacquer or other flammable materials are to be sprayed, ALWAYS locate the sprayer outside the immediate spraying area. Failure to do so may cause an explosion.

11. Locate the sprayer outside the immediate spraying area to avoid clogged air intake of the engine or electric motor with overspray.

Preparing a New Sprayer

If this sprayer is new, it is shipped with test fluid in the fluid section to prevent corrosion during shipment and storage. This fluid must be thoroughly cleaned out of the system with mineral spirits before you begin spraying.

⚠ CAUTION

Always keep the trigger lock on the spray gun in the locked position while preparing the system.

1. Place the siphon tube into a container of mineral spirits.
2. Place the bleed hose into a metal waste container.
3. Set the pressure to minimum by turning the pressure control knob fully counterclockwise.

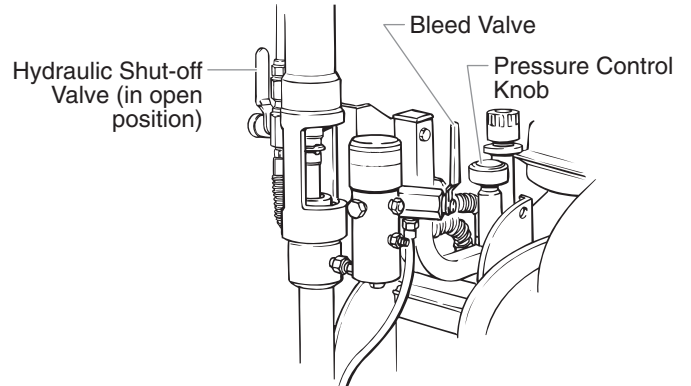

4. Open the hydraulic shut-off valve located on the hydraulic pressure hose. The handle should be in line with the hose.
5. Open the bleed valve by rotating the bleed valve handle fully counterclockwise.
6. Start the engine or turn on the electric motor.

a. To start the gas engine,

- move the fuel valve lever to the open position,
- move the throttle lever to its middle point,
- move the choke lever to the closed position for a cold engine or to the open position for a warm engine,

- turn the engine switch to the ON position, and
- pull the starter rope briskly until the engine starts.

b. To start the electric motor, move the ON/OFF switch to the ON position.

7. Turn the pressure control knob clockwise approximately 1/3 of the way down to increase pressure until the sprayer cycles evenly and solvent flows freely from the bleed hose.
8. Allow the sprayer to run for 15–30 seconds to flush the test fluid out through the bleed hose and into the waste container.
9. Turn off the sprayer.
 - a. To turn off the gas engine,
 - set the pressure to minimum by turning the pressure control knob fully counterclockwise,
 - move the throttle lever to the slow position, and
 - turn the engine switch to the OFF position.
 - b. To turn off the electric motor,
 - set the pressure to minimum by turning the pressure control knob fully counterclockwise,
 - move the ON/OFF switch to the OFF position.

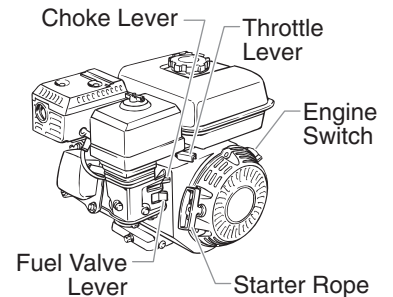

Preparing to Paint

Before painting, it is important to make sure that the fluid in the system is compatible with the paint that is going to be used.

NOTE: Incompatible fluids and paint may cause the valves to become stuck closed, which would require disassembly and cleaning of the sprayer's fluid section.

CAUTION

Always keep the trigger lock on the spray gun in the locked position while preparing the system.

1. Place the siphon tube into a container of the appropriate solvent.

NOTE: If you are spraying a water-based latex, flush with warm, clean water. If you are using any other material, check with the material manufacturer for a compatible solvent.

2. Place the bleed hose into a metal waste container.
3. Set the pressure to minimum by turning the pressure control knob fully counterclockwise.
4. Open the hydraulic shut-off valve located on the hydraulic pressure hose. The handle should be in line with the hose.
5. Open the bleed valve by rotating the bleed valve handle fully counterclockwise.
6. Start the engine or turn on the electric motor.
 - a. To start the gas engine,
 - move the fuel valve lever to the open position,
 - move the throttle lever to its middle point,
 - move the choke lever to the closed position for a cold engine or to the open position for a warm engine,
 - turn the engine switch to the ON position, and
 - pull the starter rope briskly until the engine starts.
 - b. To start the electric motor, move the ON/OFF switch to the ON position.
7. Turn the pressure control knob clockwise approximately 1/3 of the way down to increase pressure until the sprayer cycles evenly and solvent flows freely from the bleed hose.
8. Allow the sprayer to run for 15–30 seconds to flush the test fluid out through the bleed hose and into the waste container.
9. Turn off the sprayer.
 - a. To turn off the gas engine,
 - set the pressure to minimum by turning the pressure control knob fully counterclockwise,
 - move the throttle lever to the slow position, and
 - turn the engine switch to the OFF position.
 - b. To turn off the electric motor,
 - set the pressure to minimum by turning the pressure control knob fully counterclockwise,
 - move the ON/OFF switch to the OFF position.

NOTE: Make sure that the spray gun does not have a tip or tip guard installed.

10. Close the bleed valve by rotating the bleed valve handle fully clockwise.
11. Start the engine or turn on the electric motor.
12. Turn the pressure control knob clockwise approximately 1/3 of the way down to increase pressure.
13. Unlock the gun by turning the gun trigger lock to the unlocked position.

WARNING

Ground the gun by holding it against the edge of the metal container while flushing. Failure to do so may lead to a static electric discharge, which may cause a fire.



14. Trigger the gun into the metal waste container until the old solvent is gone and fresh solvent is coming out of the gun.
15. Lock the gun by turning the gun trigger lock to the locked position.
16. Set down the gun and increase the pressure by turning the pressure control knob slowly clockwise.
17. Check the entire system for leaks. If leaks occur, follow the "Pressure Relief Procedure" in this manual before tightening any fittings or hoses.
18. Follow the "Pressure Relief Procedure" in this manual before changing from solvent to paint.



Trigger lock in locked position.

WARNING

Be sure to follow the pressure relief procedure when shutting the sprayer down for any purpose, including servicing or adjusting any part of the spray system, changing or cleaning spray tips, or preparing for cleanup.

Painting

1. Place the siphon tube into a container of paint.
2. Place the bleed hose into a metal waste container.
3. Set the pressure to minimum by turning the pressure control knob fully counterclockwise.

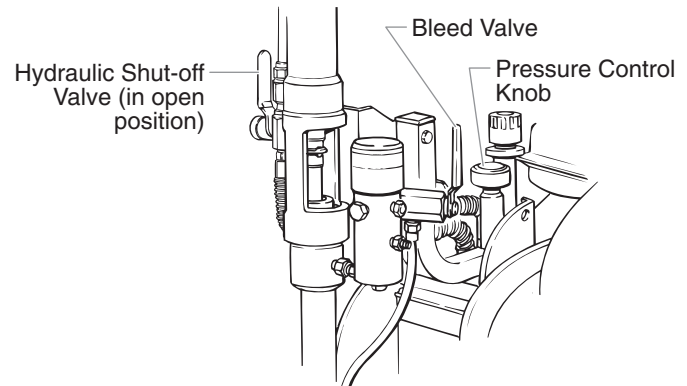

4. Open the hydraulic shut-off valve located on the hydraulic pressure hose. The handle should be in line with the hose.
5. Open the bleed valve by rotating the bleed valve handle fully counterclockwise.
6. Start the engine or turn on the electric motor.
 - a. To start the gas engine,

- move the fuel valve lever to the open position,
- move the throttle lever to its middle point,
- move the choke lever to the closed position for a cold engine or to the open position for a warm engine,

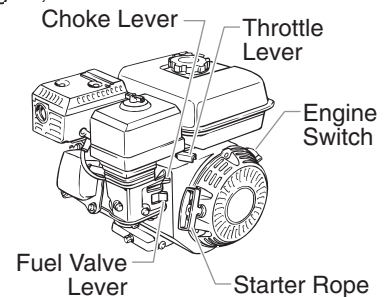

- turn the engine switch to the ON position, and
- pull the starter rope briskly until the engine starts.

- b. To start the electric motor, move the ON/OFF switch to the ON position.
7. Turn the pressure control knob clockwise approximately 1/3 of the way down to increase pressure until the sprayer cycles evenly and paint flows freely from the bleed hose.
8. Turn off the sprayer.
 - a. To turn off the gas engine,
 - set the pressure to minimum by turning the pressure control knob fully counterclockwise,
 - move the throttle lever to the slow position, and
 - turn the engine switch to the OFF position.
 - b. To turn off the electric motor,
 - set the pressure to minimum by turning the pressure control knob fully counterclockwise,
 - move the ON/OFF switch to the OFF position.
9. Remove the bleed hose from the waste container and place it into the container of paint.
10. Close the bleed valve by rotating the bleed valve handle fully clockwise.
11. Start the engine or turn on the electric motor.
12. Turn the pressure control knob clockwise approximately 1/3 of the way down to increase pressure.
13. Unlock the gun by turning the gun trigger lock to the unlocked position.

⚠ WARNING

Ground the gun by holding it against the edge of the metal container while flushing. Failure to do so may lead to a static electric discharge, which may cause a fire.



14. Trigger the gun into the metal waste container until all air and solvent is flushed from the spray hose and paint is flowing freely from the gun.
15. Lock the gun by turning the gun trigger lock to the locked position.
16. Turn off the sprayer.
17. Attach tip guard and tip to the gun as instructed by the tip guard or tip manuals.

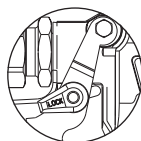

Trigger lock in locked position.

⚠ WARNING

POSSIBLE INJECTION HAZARD. Do not spray without the tip guard in place. Never trigger the gun unless the tip is in either the spray or the unclog position. Always engage the gun trigger lock before removing, replacing or cleaning tip.

18. Start the engine or turn on the electric motor.
19. Increase the pressure by turning the pressure control knob slowly clockwise and test the spray pattern on a piece of cardboard. Adjust the pressure control knob until the spray from the gun is completely atomized.

NOTE: Turning the pressure up higher than needed to atomize the paint will cause premature tip wear and additional overspray.

Pressure Relief Procedure

⚠ WARNING

Be sure to follow the pressure relief procedure when shutting the sprayer down for any purpose, including servicing or adjusting any part of the spray system, changing or cleaning spray tips, or preparing for cleanup.

1. Lock the gun by turning the gun trigger lock to the locked position.
2. Turn off the sprayer.
 - a. To turn off the gas engine,
 - set the pressure to minimum by turning the pressure control knob fully counterclockwise,
 - move the throttle lever to the slow position, and
 - turn the engine switch to the OFF position.
 - b. To turn off the electric motor,
 - set the pressure to minimum by turning the pressure control knob fully counterclockwise,
 - move the ON/OFF switch to the OFF position.
3. Close the hydraulic shut-off valve on the hydraulic pressure hose.
4. Unlock the gun by turning the gun trigger lock to the unlocked position.
5. Hold the metal part of the gun firmly to the side of a metal waste container to ground the gun and avoid a build up of static electricity.
6. Trigger the gun to remove any pressure that may still be in the hose.
7. Lock the gun by turning the gun trigger lock to the locked position.
8. Place the bleed hose into the metal waste container.
9. Open the bleed valve by rotating the bleed valve handle fully counterclockwise.

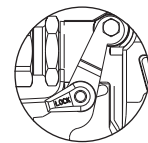

Trigger lock in locked position.

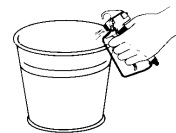

Cleanup

⚠ WARNING

Special cleanup instructions for use with flammable solvents:

- Always flush spray gun preferably outside and at least one hose length from spray pump.
- If collecting flushed solvents in a one gallon metal container, place it into an empty five gallon container, then flush solvents.
- Area must be free of flammable vapors.
- Follow all cleanup instructions.

⚠ CAUTION

The sprayer, hose, and gun should be cleaned thoroughly after daily use. Failure to do so permits material to build up, seriously affecting the performance of the sprayer.

⚠ WARNING

Always spray at minimum pressure with the gun nozzle tip removed when using mineral spirits or any other solvent to clean the sprayer, hose, or gun. Static electricity buildup may result in a fire or explosion in the presence of flammable vapors.

1. Follow the "Pressure Relief Procedure" found in the Operation section of this manual.
2. Remove the gun tip and tip guard and clean with a brush using the appropriate solvent.

- Place the siphon tube into a container of the appropriate solvent.

CAUTION

Use only compatible solvents when cleaning out oil based enamels, lacquers, coal tar, and epoxies. Check with the fluid manufacturer for the recommended solvent.

- Place the bleed hose into a metal waste container.
- Set the pressure to minimum by turning the pressure control knob fully counterclockwise.

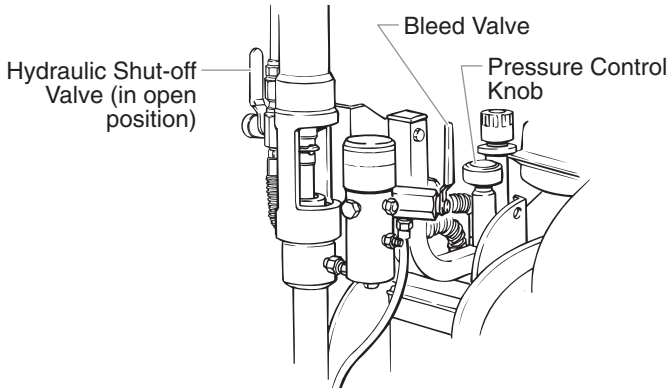

- Open the hydraulic shut-off valve located on the hydraulic pressure hose. The handle should be in line with the hose.
- Open the bleed valve by rotating the bleed valve handle fully counterclockwise.
- Start the engine or turn on the electric motor.
- Allow the solvent to circulate through the sprayer and flush the paint out of the bleed hose into the metal waste container.
- Turn off the sprayer.
- Close the bleed valve by rotating the bleed valve handle fully clockwise.
- Start the engine or turn on the electric motor.

WARNING

Ground the gun by holding it against the edge of the metal container while flushing. Failure to do so may lead to a static electric discharge, which may cause a fire.



- Trigger the gun into the metal waste container until the paint is flushed out of the hose and solvent is coming out of the gun.
- Continue to trigger the spray gun into the waste container until the solvent coming out of the gun is clean.

NOTE: For long-term or cold weather storage, pump mineral sprits through the entire system.

- Follow the "Pressure Relief Procedure" found in the Operation section of this manual.
- Store the sprayer in a clean, dry area.

CAUTION

Do not store the sprayer under pressure.

Cleaning a Clogged Tip

- Follow the "Pressure Relief Procedure" in the Operation section of this manual.
- If the tip clogs, rotate the tip handle 180° until the arrow on the handle is facing the opposite of the spray direction and the handle clicks in the reverse position.
- Trigger the gun once so that the pressure can blow the clog out. NEVER use the tip in the reverse position for more than ONE trigger pull at a time. This procedure can be repeated until the tip is free of clogging.

WARNING

The flow from the spray tip is at very high pressure. Contact with any body part may be dangerous. Do not place finger on gun outlet. Do not point the gun at any person. Never operate the spray gun without the proper tip guard.

Maintenance

WARNING

Before proceeding, follow the Pressure Relief Procedure outlined previously in this manual. Additionally, follow all other warnings to reduce the risk of an injection injury, injury from moving parts or electric shock. Always unplug the sprayer before servicing!

Daily Maintenance

Two daily procedures are required for routine operator maintenance on this sprayer:

- Lubricating the upper packings.
- Cleaning the rock catcher.

Lubricating the Upper Packings

- Clean out the paint that has seeped past the upper packings into the packing oil cup above the fluid section.
- Fill the packing oil cup 1/2 full with Piston Lube (P/N 314-480) supplied by the factory. This will extend packing life.



NOTE: Do not over-fill the oil cup so that it overflows and drips into the paint.

Cleaning the Inlet Screen

The inlet screen will clog and must be cleaned at least once a day.

- Loosen and remove the inlet screen from the siphon tube.
- Clean thoroughly with the appropriate solvent.

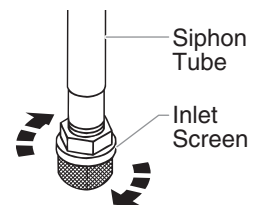

Maintaining the Filter Assembly

Clean the filter regularly. Dirty or clogged filters can greatly reduce filtering ability and cause a number of system problems including poor spray patterns, clogged spray tips, etc.

Cleaning

To clean the filter, perform the following procedure.

1. Follow the "Pressure Relief Procedure" found in the Operation section of this manual.
2. Remove the filter cap assembly and spring.
3. Pull the filter element with ball straight out of the filter body.
4. Clean inside the filter body, filter element with ball, and filter cap assembly using the appropriate solvent.

NOTE: Use care in handling parts as dirt, debris, scratches, or nicks may prevent o-rings or gaskets from sealing. This filter element filters from the inside out. Be sure to clean the filter element thoroughly on the inside. Soak in solvent to loosen hardened paint or replace.

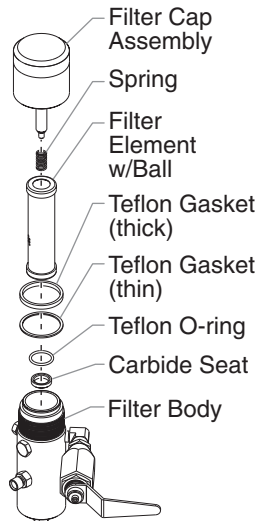

Inspection

Inspect all parts of the filter assembly before reassembly.

1. Inspect the ball inside the filter element. If the ball has pressure cuts or scratches, replace the filter element.
 - a. If the ball is cut, remove the Teflon o-ring using an o-ring pick and remove the carbide seat.
 - b. Check the seat for nicks or grooves. If the seat is damaged, replace.

NOTE: Removal of the Teflon o-ring will damage the o-ring and require replacement.

2. Remove the spring from the spring guide on the filter cap.
 - a. Measure the length of the spring uncompressed. If it measures less than 3/4" from end to end, replace.
 - b. Push the spring back onto the spring guide until it "snaps" back into position.
3. Inspect the two Teflon gaskets and the Teflon o-ring for deformity, nicks, or cuts. Replace, if needed.

NOTE: The Teflon gaskets, Teflon o-ring, and spring are packaged in Filter Service Kit P/N 930-050.

Reassembly

After cleaning and inspecting all parts, reassemble the filter.

1. Place the carbide seat into the filter body. Make sure the beveled side of the seat is facing up.
2. Place the Teflon o-ring into the groove on the outer diameter of the carbide seat.
3. Place the filter element with ball into the filter body.

NOTE: The top and bottom of the filter element with ball are identical.

4. Push the spring back onto the spring guide of the filter cap until it "snaps" back into position, if not already done.
5. Place the thin Teflon gasket onto the step at the top of the filter body.
6. Place the thick Teflon gasket onto the top of the thin gasket.
7. Tighten the filter cap assembly onto the filter body.

Maintaining the Hydraulic System

CAUTION

Use of Speeflo's Coolflo™ Hydraulic Fluid is mandatory in the PowrTwin hydraulic system. Do not use any other hydraulic fluid. Use of any other hydraulic fluid may seriously damage the hydraulic system and will void the warranty.

1. Check the hydraulic fluid daily. It should be at the "Full" mark on the dipstick. If it is low, add only Speeflo Coolflo™ Hydraulic Fluid (P/N 430-361). Never add or change hydraulic fluid except in a clean, dust-free area. Contamination of the hydraulic fluid will shorten hydraulic pump life and may void warranty.

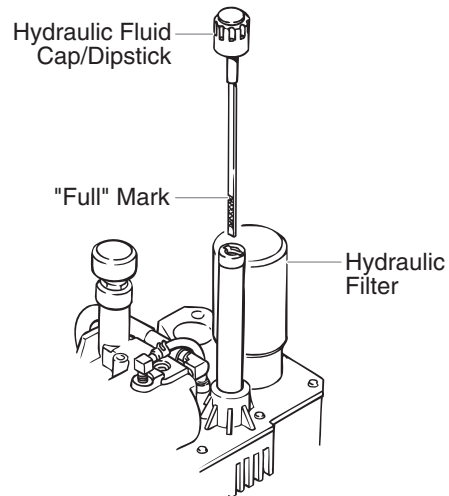

2. Change the hydraulic fluid every twelve months. Drain the old fluid from the tank and fill with 4 quarts of Speeflo Coolflo™ Hydraulic Fluid. Start the sprayer at just enough pressure to operate the fluid section. Run the sprayer at this low pressure for at least 5 minutes. This removes air from the system. Check the fluid level after this procedure. Do not over-fill.

NOTE: When replacing the hydraulic filter during a fluid change, it may be necessary to add up to one additional quart of hydraulic fluid.

3. The hydraulic system has an external, replaceable hydraulic filter. Change the filter every twelve months.
4. The hydraulic pump should not be serviced in the field. If service on the hydraulic pump is required, it must be returned to Speeflo.

Maintaining the Fluid Section

If the sprayer is going to be out of service for an extended period of time, it is recommended that following cleanup a kerosene and oil mixture be introduced as a preservative. Packings may tend to dry out from lack of use. This is particularly true of the upper packing set for which upper packing lubricant Piston Lube (P/N 314-480) is recommended in normal usage.

If the sprayer has been out of service for an extended period of time, it may be necessary to prime the pump with solvent. It is extremely important that the threads on the siphon tube/hose coupling are properly sealed. Any air leakage will produce erratic operation of the sprayer and may damage the system. The up and the down strokes should be approximately equal in time (one should not be faster than the other). A fast up or down stroke may indicate air in the system or malfunctioning valve or seats (see the Troubleshooting section).

Basic Engine Maintenance (gas engine)

- For detailed engine maintenance and technical specifications refer to the separate gasoline engine manual.
- All service to the engine should be performed by an authorized Honda Power Equipment dealer. To locate a dealer in your area, look in the Yellow Pages of your telephone directory under Gasoline Engines, Garden & Lawn Equipment & Supplies, Lawn Mowers, etc.
- The Honda engine is warranted exclusively by American Honda Motor Co., Inc.
- Use a premium quality motor oil certified to meet or exceed U.S. Automotive requirement SG.or SF. SAE 10W30 is recommended for general all temperature use. Other viscosities may be required in other climates.
- Use only a (NGK) BP6ES or BPR6E spark plug. Gap the plug to 0.028 to 0.031 In. (0.7 to 0.8 mm) Always use a spark plug wrench.

Daily

1. Check engine oil level, and fill as necessary.
2. Check gasoline level, and fill as necessary.

⚠ WARNING

Always follow the fueling procedure outlined earlier in this manual.

First 20 Hours

1. Change engine oil.

Every 100 Hours

1. Change engine oil.
2. Clean the sediment cup.
3. Clean and re-gap the spark plug.
4. Clean the spark arrestor.

Weekly

1. Remove the air filter cover and clean the element. In very dusty environments, check the filter daily. Replace the element as needed. Replacement elements can be purchased from your local Honda dealer.

Engine Operation and Service

1. Clean and oil air filter pad on gasoline engine every 25 hours or once weekly. Do not permit the air intake screen around the fly wheel of the gas engine to load up with paint or trash. Clean it regularly. The service life and efficiency of the gas engine model depends upon keeping the gasoline engine running properly. Change the oil in the engine every 100 hours. Failure to observe this may result in engine overheating. Consult the engine manufacturer's service manual provided.
2. To conserve fuel, service life, and efficiency of the sprayer, always operate the gasoline engine at the lowest RPM at which it runs smoothly without laboring and delivers the amount required for the particular painting operation. Higher RPM does not produce higher working pressure. The gasoline engine is connected to the hydraulic pump by a pulley combination designed to produce full paint delivery at maximum RPM.
3. The warranty on gasoline engines or electric motors is limited to the original manufacturer.

Replacing the Motor Brushes (electric motor)

Perform this procedure using Motor Brush Kit P/N 978-050. The kit consists of two brushes, two springs, and two clips.

NOTE: Brushes should be replaced when they are worn to less than 1/2 inch. Check and replace both brushes at the same time.

1. Remove both inspection covers on the motor.

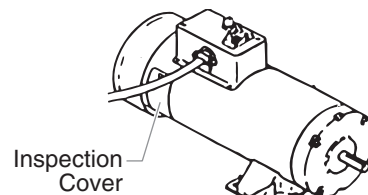

2. Push in the spring clip to unhook it, then pull it out..

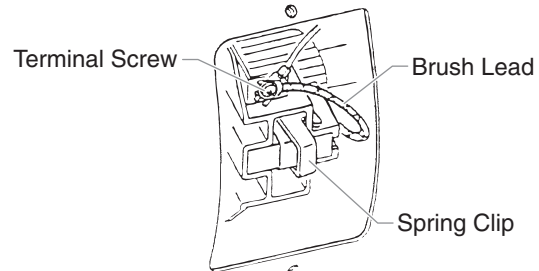

3. Loosen the terminal screw. Pull the brush lead away, but leave the motor lead in place. Remove the brush and spring.
4. Inspect the commutator for burning, excessive pitting or gouging. A black color on the commutator is normal.

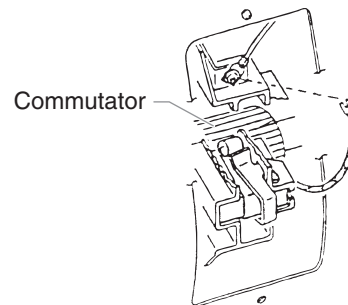

5. Install the new brush so its lead slides in the long slot of the brush holder. Push the terminal under the terminal screw washer. Ensure the motor lead is still connected at the screw. Tighten the screw.

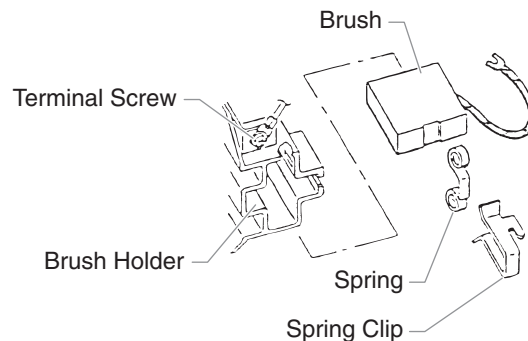

6. Place the spring on the brush as shown above. Push in and hook the spring clip. Repeat this procedure for the other side.
7. Reinstall both inspection covers.

⚠ WARNING

If electric motor overloads and stops running, IMMEDIATELY turn the motor off and follow the Pressure Relief Procedure in the Cleanup section of this manual. Wait until the motor cools (approximately 30 minutes). Then push in the bubble top, manual reset button, turn the motor on and pressurize the system.

For CSA approved sprayers only: The ON/OFF switch is also the RESET!

Troubleshooting

Airless Gun

Problem

Spitting gun

Cause

1. Air in system
2. Dirty gun
3. Needle assembly out of adjustment
4. Broken or chipped seat

Solution

1. Inspect connections for air leaks.
2. Disassemble and clean.
3. Inspect and adjust.
4. Inspect and replace.

Gun will not shut off

1. Worn or broken needle & seat
2. Needle assembly out of adjustment
3. Dirty gun

1. Replace.
2. Adjust.
3. Clean.

Gun does not spray

1. No paint
2. Plugged filter or tip
3. Broken needle in gun

1. Check fluid supply.
2. Clean.
3. Replace.

Fluid Section

Problem

Pump delivers on upstroke only or goes up slowly and down fast (commonly called downstroke dive)

Cause

1. Lower foot valve ball is not seating due to trash or wear
2. Material too viscous to siphon.
3. Air leaking in on siphon side or damaged siphon hose. Siphon may be too small for heavy material.

Solution

1. Remove foot valve assembly. Clean and inspect. Test foot valve by filling with water; if ball fails to seal the seat, replace ball.
2. Thin material — contact manufacturer for proper thinning procedures.
3. Tighten all connections between pump and paint container. If damaged, replace. Switch to larger diameter siphon set.

Pump delivers on down stroke only or goes up fast and down slowly

1. Upper ball is not seating due to trash or wear
2. Lower packing set is worn

1. Check upper seat and ball with water. If ball fails to seal, replace seat.
2. Replace packing set if worn.

Pump moves up and down fast, delivering material

1. Material container is empty or material is too thick to flow through siphon hose
2. Bottom ball stuck to foot valve seat
3. Siphon hose is kinked or loose

1. Refill with new material. If too thick, remove siphon hose, immerse fluid section in material, and start pump to prime. Add thinner to material. Change to bigger siphon set. Open bleed valve to remove air and restart pump.
2. Remove foot valve. Clean ball and seat.
3. Straighten.

Pump moves up and down slowly when spray gun is shut off

1. Loose connections. Bleed valve is open partially or bleed valve is worn. Lower packing seat is worn.
2. Upper and/or lower ball not seating

1. Check all connections between pump and gun. Tighten as necessary. If material is flowing from bleed hose, close bleed valve or replace, if necessary. Should none of the above be evident, replace lower packing.
2. Reseat balls by cleaning.

Not enough fluid pressure at gun

1. Spray tip is worn
2. Outlet filter or gun filter is clogged
3. Low voltage and/or inadequate amperage
4. Hose size or length is too small or too long

1. Replace.
2. Clean or replace filter.
3. Check electrical service. Correct as required.
4. Increase hose size to minimize pressure drop through hose and/or reduce hose length.

Pump chatters on up or down stroke

1. Solvent has caused upper packing to swell

1. Replace packing.

Troubleshooting

Hydraulic Motor

Problem

Oil motor stalls at bottom (no unusual heat problems)

Cause

1. Fluid pump piston seat unthreaded
2. Valve sticking or oil motor trip rod shifter assembly separated

Solution

1. If connecting rod is okay, remove cylinder head plug and pop valve down. Replace plug and start machine. If machine cycles up and stops at bottom again, then problem is piston seat on fluid pump. Check piston seat. Repair or replace as necessary. If piston seat is okay and problem does not change, check oil motor.
2. Remove valve and check for scratches and rough movement when sliding it up and down. Replace valve and spool in this condition. Check trip rod for possible separation and spool in this condition. Check trip rod for possible separation.

Oil motor stalls at top (no unusual heat problems)

1. Valve sticking
2. Broken spring retainer (valve rod assembly)
3. Broken spring or valve rod
4. Air in hydraulic motor

1. Remove valve and check for scratches and rough movement when sliding it up and down. Replace valve and spool in this condition.
2. Replace valve rod assembly.
3. Replace valve rod assembly.
4. Reset valve. Purge Air, generally accomplished by low pressure cycling of motor/pump assembly for 5–10 minutes. Check for causes of air introduction:
 - Loose fittings in tank.
 - Loose fittings on hydraulic pump.
 - Loose hose connections.
 - Low oil in reservoir.
5. Stall at top can occur randomly when fluid pump picks up air. Reset valve. Avoid air in the fluid pump.

Low pressure (okay on down stroke, sluggish on up.stroke — high heat)

NOTE: Engine labors on upstroke, idles back at stall on the down stroke.

1. Blown piston seal
2. Cracked piston

1. Before dismantling oil motor, start machine. With pump cycling under pressure, touch the hydraulic cylinder and the head to see if cylinder or head gets hotter. This will help determine if piston seal is blown or piston nut is broken. If heat is on the head, check the o-rings on spool valve.
2. Dismantle oil motor and check piston seals cylinder bore and piston nut. Pay special attention to piston nut. It can be cracked and not show externally.

Low pressure (both strokes - high heat)

NOTE: Engine labors at stall on both strokes.

1. Blown center o-rings on spool valve
2. Bad hydraulic pump

1. Before dismantling oil motor, start machine. With pump cycling under pressure, touch the head to see if the head becomes hotter. This will help determine if center o-ring is blown on spool valve. If hot, remove and replace o-ring.
2. Replace hydraulic pump.

Troubleshooting

Spray Patterns

Problem

Tails

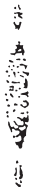

Cause

1. Inadequate fluid delivery

Solution

1. Fluid not atomizing correctly:
Increase fluid pressure. Change to smaller tip orifice size. Reduce fluid viscosity. Reduce hose length. Clean gun and filter(s). Reduce number of guns using pump.

Hour glass

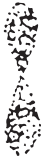

1. Inadequate fluid delivery

1. Same as above.

Distorted



1. Plugged or worn nozzle tip

1. Clean or replace nozzle tip.

Pattern expanding and contracting (surge)



1. Suction leak
2. Pulsating fluid delivery

1. Inspect for suction hose leak.
2. Change to a smaller tip orifice size. Install pulsation dampener in system or drain existing one. Reduce number of guns using pump. Remove restrictions in system; clean tip screen if filter is used.

Round pattern



1. Worn tip
2. Fluid too heavy for tip

1. Replace tip.
2. Increase pressure. Thin material. Change nozzle tip.

Consignes de sécurité

Le présent manuel comprend des renseignements devant être lus attentivement avant toute utilisation de l'appareil. Lorsque l'un des symboles suivants apparaît, il est recommandé d'être particulièrement attentif et de tenir compte des mesures de sécurité indiquées.

⚠ AVERTISSEMENT

Ce symbole indique un danger potentiel pouvant causer des blessures graves ou même mortelles. Des renseignements importants sur la sécurité sont également indiqués.

⚠ ATTENTION

Ce symbole indique un danger potentiel pouvant causer des blessures corporelles ou des dommages à l'équipement. Des renseignements importants sur la façon de prévenir tout dommage à l'équipement ou toute blessure corporelle mineure sont également indiqués.

NOTA : Les remarques donnent des renseignements importants requérant une attention particulière.

⚠ AVERTISSEMENT

CONSIGNES DE SÉCURITÉ IMPORTANTES

- A. CONSERVEZ CES CONSIGNES – Pour réduire les risques d'incendie ou d'explosion, d'électrocution et de blessures, lisez et assurez-vous de bien comprendre toutes les consignes contenues dans ce manuel. Familiarisez-vous avec les commandes et l'usage correct de l'équipement.**
- B. AVERTISSEMENT – Pour réduire le risque d'incendie ou d'explosion :**
 1. Ne pulvérisez pas de matières inflammables ou combustibles près d'une flamme nue, de voyants lumineux ou de sources d'ignition telles que des objets chauds, cigarettes, moteurs, matériel et appareils électriques. Évitez de produire des étincelles en connectant et en déconnectant les cordons électriques.
 2. Pour les appareils destinés à n'utiliser que des produits à l'eau – Ne pulvérisez pas et ne les nettoyez pas avec des liquides inflammables. Exclusivement pour usage avec liquides à base d'eau.
 3. Pour les appareils destinés à un usage exclusif avec des produits à l'eau ou des produits minéraux de type alcool avec un point d'éclair minimum de 21 °C (70 °F) – Ne pulvérisez pas et ne les nettoyez pas avec des liquides ayant un point d'éclair inférieur à 21 °C (70 °F). Le point d'éclair est la température à laquelle un fluide peut produire suffisamment de vapeur pour s'enflammer.
 4. L'écoulement de peinture ou de solvant dans l'équipement peut produire de l'électricité statique. L'électricité statique crée un risque d'incendie ou d'explosion en présence de fumées de peinture ou de solvant. Toutes les pièces du système du pulvérisateur, y compris la pompe, l'ensemble du tuyau, le pistolet de pulvérisation et les objets dans et autour de la zone de pulvérisation doivent être correctement reliés à la terre pour protéger contre les décharges d'électricité statique et les étincelles. N'utilisez que des tuyaux conducteurs ou reliés à la terre pour pulvérisateurs de peinture sous vide à haute pression, spécifiés par le fabricant.
 5. Vérifiez que tous les conteneurs ou systèmes de stockage sont reliés à la terre pour éviter les décharges d'électricité statique.
 6. Connectez à une prise électrique avec prise de terre et utilisez des rallonges électriques reliées à la terre. N'utilisez pas d'adaptateur 3 à 2.
 7. N'utilisez pas de peinture ou de solvant contenant du halon, par exemple, le chlore, les agents antimoisissure à l'eau de Javel, le chlorure de méthylène et le trichloroéthane. Ils ne sont pas compatibles avec l'aluminium. Contactez le fournisseur de revêtements pour connaître la compatibilité du matériau avec l'aluminium.
 8. La zone de pulvérisation doit toujours être bien aérée. Une bonne quantité d'air frais doit constamment traverser la zone de pulvérisation pour éviter les accumulations de vapeurs inflammables. Le système de pompage doit être placé dans une zone bien aérée. Ne pulvérisez pas le système de pompage.
 9. Ne fumez pas dans la zone de pulvérisation.
 10. N'actionnez pas d'interrupteurs électriques, de moteurs ou autres dispositifs produisant des étincelles dans la zone de pulvérisation.

11. Maintenez la propreté de la zone et veillez à ce qu'elle ne contienne pas de conteneurs de peinture ou de solvant, de chiffons et autres matières inflammables.
12. Sachez ce que contiennent la peinture et les solvants pulvérisés. Lisez les fiches de sécurité du matériel (MSDS) et les étiquettes apposées sur les conteneurs de peintures et de solvants. Respectez les consignes de sécurité du fabricant de peinture et de solvant.
13. Placez la pompe à une distance minimum de 7,62 mètres (25 pieds) de l'objet à pulvériser, dans une zone bien aérée (ajoutez de la longueur de tuyau si besoin est). Les vapeurs inflammables sont souvent plus lourdes que l'air. La zone près du sol doit être très bien aérée. La pompe contient des pièces qui produisent des arcs et émettent des étincelles pouvant enflammer les vapeurs.
14. Le plastique peut causer des étincelles d'électricité statique. N'accrochez aucun plastique dans une zone de pulvérisation fermée. N'utilisez pas de toiles de protection en plastique quand vous pulvérisez une matière inflammable.
15. Ayez un extincteur en bon état de fonctionnement à portée de main.

⚠ AVERTISSEMENT

C. AVERTISSEMENT – Pour réduire le risque de pénétration dans la peau :

DANGER :

Blessure par injection – Le jet de fluide à haute pression produit par cet équipement peut transpercer la peau et les tissus sous-jacents, ce qui produit de graves blessures et peut entraîner une amputation. Consultez immédiatement un médecin. NE TRAITEZ PAS UNE INJECTION COMME UNE SIMPLE COUPURE.

1. Ne dirigez pas le pistolet sur et ne pulvérisez pas les personnes ou les animaux.
2. N'approchez pas les mains ni d'autres parties du corps de la sortie du produit. Par exemple, ne tentez pas d'arrêter une fuite avec une partie du corps.
3. Utilisez toujours le protège-embout de la buse. Ne pulvérisez pas sans que le protège-embout de la buse ne soit installé.
4. Utilisez exclusivement un embout de buse spécifié par le fabricant.
5. Prenez garde quand vous nettoyez ou que vous changez les embouts de buse. Si l'embout se bouche pendant que vous pulvérisez, verrouillez TOUJOURS la détente du pistolet, arrêtez la pompe et libérez toute la pression avant de réparer ou de nettoyer l'embout ou le protecteur ou avant de changer d'embout. La pression n'est pas libérée par l'arrêt du moteur. La poignée du robinet-valve PRIME/SPRAY (AMORÇAGE/PULVÉRISATION) doit être placée sur PRIME pour libérer la pression. Consultez la PROCÉDURE DE LIBÉRATION DE PRESSON décrite dans le manuel de la pompe.
6. Ne laissez pas l'appareil sous tension ou sous pression quand vous vous en éloignez. Quand vous n'utilisez pas l'appareil, éteignez-le et libérez la pression conformément aux instructions du fabricant.
7. La pulvérisation à haute pression peut injecter des toxines dans le corps et causer de graves blessures corporelles. Si une telle injection se produisait, consultez immédiatement un médecin.
8. Vérifiez les tuyaux et les pièces pour détecter des signes d'endommagement : une fuite peut injecter le produit dans la peau. Inspectez le tuyau avant chaque emploi. Changez tous les tuyaux ou pièces endommagés.
9. Ce système peut produire une pression de 3300 PSI / 22.8 MPa. N'utilisez que les pièces de rechange ou les accessoires spécifiés par le fabricant et ayant une pression nominale minimum de 3300 PSI. Ceci est valable pour les embouts de pulvérisation, les protecteurs de buse, les pistolets, les rallonges, les raccords et le tuyau.
10. Verrouillez toujours la détente quand vous ne pulvérisez pas. Vérifiez que le verrou de la détente fonctionne correctement.
11. Vérifiez que toutes les connexions sont bien serrées avant d'utiliser l'appareil.
12. Sachez comment arrêter l'appareil et le dépressuriser rapidement. Soyez bien familiarisé avec les commandes. La pression n'est pas libérée lorsque le moteur est arrêté. La poignée du robinet-valve PRIME/SPRAY (AMORÇAGE/PULVÉRISATION) doit être placée sur PRIME pour libérer la pression. Consultez la PROCÉDURE DE LIBÉRATION DE PRESSON décrite dans le manuel de la pompe.

13. Retirez toujours l'embout de pulvérisation avant de rincer ou de nettoyer le système.

⚠ AVERTISSEMENT

D. AVERTISSEMENT – Pour réduire le risque de blessure :

1. Portez toujours les gants, la protection oculaire, les vêtements et un respirateur ou masque appropriés quand vous peignez. Vapeurs dangereuses – Les peintures, solvants, insecticides et autres matières peuvent être dangereux s'ils sont inhalés ou entrent en contact avec le corps. Les vapeurs peuvent provoquer d'importantes nausées, une perte de connaissance ou un empoisonnement.
2. Ne travaillez pas et ne pulvérisez pas près d'enfants. Éloignez toujours les enfants de l'équipement.
3. Ne travaillez pas avec les bras au-dessus de la tête ni sur un support instable. Appuyez-vous bien sur les deux pieds pour toujours conserver l'équilibre.
4. Soyez attentif et regardez ce que vous faites.
5. N'utilisez pas l'appareil quand vous êtes fatigué ou sous l'influence de drogues ou d'alcool.
6. Ne faites pas de nœuds avec le tuyau et ne le tordez pas trop. Le tuyau à vide peut présenter des fuites suite à l'usure, les nœuds ou les mauvais traitements. Une fuite risque d'injecter du produit dans la peau.
7. N'exposez pas le tuyau à des températures ou des pressions supérieures à celles spécifiées par le fabricant.
8. N'utilisez pas le tuyau pour tirer ou soulever l'équipement.
9. Utilisez la plus basse pression possible pour rincer l'équipement.
10. Respectez tous les codes locaux, étatiques et nationaux qui régulent la ventilation, la prévention d'incendies et le fonctionnement.
11. Les normes de sécurité du gouvernement des États-Unis ont été adoptées dans la loi Occupational safety and Health Act (OSHA). Ces normes, en particulier la partie 1910 des Normes générales et la partie 1926 des Normes de construction, doivent être consultées.
12. Avant chaque emploi, vérifiez tous les tuyaux pour détecter d'éventuelles coupures, fuites, abrasion ou couvercle bombé. Vérifiez l'état ou le mouvement des accouplements. Changez immédiatement le tuyau si l'une de ces conditions est vérifiée. Ne réparez jamais un tuyau de peinture. Remplacez-le par un tuyau conducteur à haute pression.
13. Ne pulvérisez pas à l'extérieur par temps venteux.
14. Débranchez toujours le cordon électrique de la prise avant de travailler sur l'équipement.

Instructions de mise à la terre

Les modèles électriques doivent être mis à la terre. La mise à la terre réduit les risques d'électrocution lors d'un court-circuit en permettant au courant de s'écouler par le fil de mise à la terre. Cet appareil est muni d'un cordon électrique avec fil de mise à la terre ainsi que d'une fiche de terre. La fiche doit être branchée sur une prise installée correctement et mise à la terre conformément à la réglementation et aux codes en vigueur.

DANGER — Une prise de terre mal branchée peut être à l'origine d'électrocutions. S'il s'avère nécessaire de réparer ou de remplacer le cordon électrique ou la fiche, ne pas brancher le fil vert de mise à la terre sur l'une ou l'autre des bornes à broche plate. Le fil recouvert d'un isolant vert avec ou sans rayures jaunes est le fil de mise à la terre et doit être branché sur la broche de mise à la terre.

Si vous ne comprenez pas les instructions de mise à la terre ou si vous n'êtes pas sûr que l'appareil est correctement mis à la terre, contactez un électricien agréé. Ne pas modifier la fiche d'origine. Si la prise ne convient pas à la fiche, faites installer la prise adéquate par un électricien agréé.

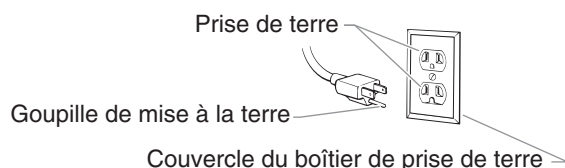

⚠ ATTENTION

Utiliser uniquement une rallonge à trois fils munie d'une fiche de terre dans une prise secteur mise à la terre correspondant au type de fiche de l'appareil. S'assurer que votre rallonge est en bon état. Lorsque vous utilisez une rallonge, assurez-vous qu'elle soit d'un calibre suffisant pour supporter l'intensité du courant requise par l'appareil. Une rallonge trop mince entraîne une chute de tension, une diminution de l'intensité et une surchauffe. Une rallonge de calibre 12 est recommandée. Si vous devez utiliser une rallonge à l'extérieur, celle-ci doit comprendre la marque W-A après la désignation indiquant le type de cordon. Par exemple, la désignation SJTW-A indique que le cordon est conçu pour être utilisé à l'extérieur.

Sécurité du moteur à essence

⚠ AVERTISSEMENT

L'État de la Californie reconnaît que les gaz d'échappement de cet appareil contiennent des produits chimiques susceptibles de causer le cancer, des malformations congénitales ou pouvant être nocifs pour le système reproducteur.

1. Les moteurs Honda sont conçus pour être fiables et sécuritaires lorsqu'ils sont utilisés selon les directives. Lire et comprendre le guide d'utilisation de Honda avant de faire fonctionner le moteur. Le non-respect de cet avertissement risque de causer des blessures graves ou d'endommager l'appareil.
2. Afin de prévenir les risques d'incendie et d'assurer une ventilation adéquate, garder le moteur à une distance d'au moins un mètre (3 pi) des bâtiments et des autres appareils durant le fonctionnement. Ne pas placer des objets inflammables près du moteur.
3. Les enfants et les animaux doivent être tenus à l'écart de la zone de fonctionnement de l'appareil afin d'éviter les risques de brûlures causées par les composants chauds du moteur ou par les équipements utilisés avec le moteur.
4. Savoir comment couper le moteur rapidement et bien comprendre le fonctionnement de toutes les commandes. Ne jamais laisser quiconque utiliser le moteur sans lui avoir d'abord fourni les directives appropriées.
5. Le carburant est une matière extrêmement inflammable et peut exploser sous certaines conditions.
6. Ravitailler en carburant dans un endroit bien aéré une fois le moteur arrêté. Ne pas fumer et s'assurer qu'il n'y ait ni flammes ni étincelles dans la zone de ravitaillement ou d'entreposage du carburant.
7. Ne pas trop remplir le réservoir d'essence. Après le ravitaillement, s'assurer que le bouchon du réservoir soit bien fermé et serré.
8. Prendre soin de ne pas renverser de carburant lors du ravitaillement, car les vapeurs émanant du carburant ou le carburant déversé accidentellement peuvent s'enflammer. En cas de déversement, s'assurer que l'endroit soit complètement sec avant de démarrer le moteur.
9. Ne jamais mettre le moteur en marche dans un endroit fermé ou restreint, car les gaz d'échappement contiennent des matières toxiques, telles que le monoxyde de carbone, susceptibles de provoquer des évanouissements ou même d'entraîner la mort.
10. Le silencieux devient très chaud durant le fonctionnement et le demeure pendant un certain temps une fois le moteur arrêté. S'assurer d'attendre quelques minutes avant de toucher au silencieux. Pour éviter les risques de brûlures graves ou d'incendie, laisser le moteur se refroidir avant de le transporter ou de l'entreposer à l'intérieur.
11. Ne jamais expédier ou transporter l'appareil lorsque le réservoir est rempli de carburant.

⚠ AVERTISSEMENT

Ne pas utiliser cet appareil pour vaporiser de l'eau ou de l'acide.

⚠ ATTENTION

Ne pas soulever par la poignée du chariot lors du chargement ou du déchargement.

Precauciones de seguridad

Este manual contiene información que debe leer y comprender antes de usar el equipo. Cuando se encuentre con uno de los siguientes símbolos, asegúrese de observar sus indicaciones de seguridad.

ADVERTENCIA

Este símbolo indica la existencia de un peligro potencial que puede causar lesiones graves o la muerte. Después del mismo se incluye información de seguridad importante.

PRECAUCION

Este símbolo indica la existencia de un peligro potencial para usted o el equipo. Después del mismo se incluye información importante que indica la forma de evitar daños al equipo o la forma de prevenir lesiones menores.

NOTA: los avisos contienen información importante, présteles especial atención.

ADVERTENCIA

INSTRUCCIONES DE SEGURIDAD IMPORTANTES

- A. GUARDE ESTAS INSTRUCCIONES – Para reducir el riesgo de incendio o explosión, descarga eléctrica y daños a las personas, lea y comprenda todas las instrucciones incluidas en este manual. Familiarícese con los controles y con el uso adecuado del equipo.**
- B. ADVERTENCIA – Para reducir el riesgo de incendio o explosión:**
 1. No pulverice materiales inflamables ni combustibles cerca de llamas desnudas, pilotos o fuentes de ignición como objetos calientes, cigarrillos, motores, equipos eléctricos o electrodomésticos. Evite producir chispas al conectar y desconectar los cables de alimentación.
 2. Para unidades que se vayan a utilizar con materiales acuosos — No pulverice ni limpie con líquidos inflamables. Para su uso con líquidos acuosos solamente.
 3. Para unidades que se vayan a utilizar solamente con materiales acuosos o de tipo de alcohol mineral con un punto de inflamación mínimo de 21 °C (69,8 °F) — No pulverice ni limpie con líquidos que tengan un punto de inflamación por debajo de 21 °C (69,8 °F). El punto de inflamación es la temperatura a la que un fluido puede producir vapor suficiente como para incendiarse.
 4. La pintura o disolvente que pase por el equipo puede producir electricidad estática. La electricidad estática supone un riesgo de incendio o explosión en presencia de emanaciones de pintura o disolvente. Todas las piezas del sistema pulverizador, incluyendo la bomba, el conjunto de mangueras, la pistola pulverizadora y los objetos dentro y alrededor de la zona de pulverización se conectarán a tierra para protegerlos frente a descargas estáticas y chispas. Utilice solamente mangueras para pulverizadores de pintura airless (sin aire) de alta presión conductoras o con toma a tierra especificadas por el fabricante.
 5. Compruebe que todos los recipientes y sistemas de recogida están conectados a tierra para evitar descargas eléctricas.
 6. Conecte a una salida con toma a tierra y utilice cables alargadores puestos a tierra. No utilice un adaptador de 3 a 2.
 7. No utilice pintura o disolvente que contenga hidrocarburos halogenados, como cloro, fungicida blanqueador, cloruro de metileno y tricloroetano. No son compatibles con el aluminio. Póngase en contacto con el proveedor del material para conocer su compatibilidad con el aluminio.
 8. Mantenga la zona de pulverización bien ventilada. Asegúrese de que circula aire fresco por la zona para evitar que se acumulen vapores inflamables en el aire de la zona de pulverización. Ponga el conjunto de la bomba en una zona bien ventilada. No pulverice el conjunto de la bomba.
 9. No fume en la zona de pulverización.
 10. No encienda interruptores de luces, motores ni productos similares que puedan producir chispas en la zona de pulverización.
 11. Mantenga la zona limpia y despejada de botes de pintura y disolventes, trapos y otros materiales inflamables.

12. Infórmese del contenido de la pintura y de los disolventes que pulverice. Lea las hojas de datos sobre seguridad de los materiales (MSDS) y las etiquetas en los botes de pintura y disolvente. Siga las instrucciones de seguridad del fabricante de la pintura y del disolvente.
13. Coloque la bomba al menos a 7,62 metros (25 pies) del objeto que se va a pulverizar en una zona bien ventilada (añada más manguera si fuera necesario). Los vapores inflamables suelen ser más pesados que el aire. La zona del suelo debe estar muy bien ventilada. La bomba contiene piezas que forman arcos que producen chispas y pueden inflamar los vapores.
14. El plástico puede producir chispas estáticas. Nunca utilice plástico para cercar la zona de pulverización. No utilice cortinas de plástico mientras pulveriza material inflamable.
15. Deberá contar con equipos extintores de incendios que funcionen correctamente.

ADVERTENCIA

C. ADVERTENCIA – Para reducir el riesgo de daños en la piel:

PELIGRO:

Lesión causada por inyección. La corriente de líquido a alta presión que produce este equipo puede perforar la piel y tejidos subcutáneos, pudiendo provocar graves lesiones y posibles amputaciones. Visite a un médico inmediatamente. NO TRATE UNA LESIÓN CAUSADA POR INYECCIÓN COMO UN SIMPLE CORTE.

1. No apunte con la pistola ni pulverice sobre ninguna persona ni animal.
2. Mantenga las manos y el resto del cuerpo lejos de la descarga. Por ejemplo, no trate de detener fugas con ninguna parte de su cuerpo.
3. Utilice siempre el protector de la boquilla. No pulverice sin el protector en su sitio.
4. Utilice solamente la boquilla especificada por el fabricante.
5. Tenga cuidado al limpiar y cambiar las boquillas. Si la boquilla se atasca durante la pulverización, ponga SIEMPRE el seguro del gatillo de la pistola, apague la bomba y libere toda la presión antes de reparar, limpiar el protector o la boquilla o cambiar la boquilla. La presión no se libera apagando el motor. Para liberar la presión hay que poner la manija de la válvula PRIME/SPRAY (cebar/pulverizar) en PRIME. Consulte el Procedimiento para liberar presión que se describe en el manual de la bomba.
6. No deje el aparato con corriente ni con presión cuando nadie esté pendiente de ella. Cuando no utilice el aparato, apáguelo y libere la presión siguiendo las instrucciones del fabricante.
7. La pulverización a alta presión puede inyectar toxinas en el cuerpo y producir daños graves en el mismo. En caso de que esto ocurra, visite a un médico inmediatamente.
8. Compruebe las mangueras y las piezas en busca de daños; una fuga puede inyectar material en la piel. Inspeccione la manguera antes de cada uso. Sustituya las mangueras o las piezas dañadas.
9. Este sistema es capaz de producir 3300 PSI / 22.8 MPa. Utilice solamente piezas de repuesto o accesorios especificados por el fabricante y con una capacidad nominal de 3300 PSI como mínimo. Entre ellos se incluyen boquillas pulverizadoras, protectores para las boquillas, pistolas, alargadores, racores y mangueras.
10. Ponga siempre el seguro del gatillo cuando no esté pulverizando. Verifique que el seguro del gatillo funciona correctamente.
11. Antes de utilizar el aparato, verifique que todas las conexiones son seguras.
12. Aprenda a detener el aparato y a liberar la presión rápidamente. Familiarícese a conciencia con los controles. La presión no se libera apagando el motor. Para liberar la presión hay que poner la manija de la válvula PRIME/SPRAY (cebar/pulverizar) en PRIME. Consulte el Procedimiento para liberar presión que se describe en el manual de la bomba.
13. Quite siempre la boquilla pulverizadora antes de enjuagar o limpiar el sistema.

⚠️ ADVERTENCIA

D. ADVERTENCIA – Para reducir el riesgo de lesiones:

1. Cuando pinte, lleve siempre guantes, protección para los ojos, ropa y un respirador o máscara adecuados. Vapores peligrosos: Las pinturas, disolventes, insecticidas y otros materiales pueden ser perjudiciales si se inhalan o entran en contacto con el cuerpo. Los vapores pueden producir náuseas intensas, desmayos o envenenamiento.
2. Nunca utilice el aparato ni pulverice cerca de niños. Mantenga el equipo alejado de los niños en todo momento.
3. No se estire demasiado ni se apoye sobre un soporte inestable. Mantenga los pies bien apoyados y el equilibrio en todo momento.
4. No se distraiga y tenga cuidado con lo que hace.
5. No utilice el aparato si está fatigado o se encuentra bajo la influencia del alcohol o de las drogas.
6. No retuerza ni doble la manguera en exceso. En la manguera airless pueden aparecer fugas a causa del desgaste, de retorcimientos o de un mal uso. Una fuga puede inyectar material en la piel.
7. No exponga la manguera a temperaturas o presiones que superen las especificadas por el fabricante.
8. No utilice la manguera como elemento de fuerza para tirar del equipo o levantarlo.
9. Utilice la presión más baja posible para enjuagar el equipo.
10. Cumpla todos los reglamentos locales, estatales y nacionales pertinentes relativos a ventilación, prevención de incendios y funcionamiento.
11. Las normas sobre seguridad del gobierno de los Estados Unidos se han adoptado al amparo de la Ley de salud y seguridad ocupacional (OSHA). Deben consultarse tres normas, particularmente la sección 1910 de las Normas generales y la sección 1926 de las Normas sobre construcción.
12. Cada vez que vaya a utilizar el equipo, compruebe antes todas las mangueras en busca de cortes, fugas, abrasión o bultos en la cubierta. Compruebe el movimiento de los acoplamientos y si están dañados. Sustituya inmediatamente una manguera si descubre alguna de estas anomalías. No repare nunca una manguera de pintura. Sustitúyala por una manguera conductora a alta presión.
13. No pulverice al aire libre si hace viento.
14. Desenchufe siempre el cable antes de trabajar en el equipo.

Instrucciones para conectar a tierra

Los modelos eléctricos deben estar conectados a tierra. En caso de que ocurra un corto circuito, la conexión a tierra reduce el riesgo de choque eléctrico al proporcionar un alambre de escape para la corriente eléctrica. Este producto está equipado con un cable que tiene un alambre de conexión a tierra con un enchufe de conexión a tierra apropiado. El enchufe se debe enchufar en una toma de corriente que se haya instalado y conectado a tierra debidamente, de acuerdo con todos los códigos y estatutos locales.

PELIGRO — Una instalación inapropiada del enchufe de conexión a tierra puede dar como resultado el que exista un riesgo de choque eléctrico. Si es necesario reparar o reemplazar el cable o el enchufe, no conecte el alambre de conexión a tierra a ninguno de los terminales de hoja planos. El alambre con aislamiento que tiene la superficie exterior de color verde con franjas amarillas o sin ellas es el alambre de conexión a tierra que debe conectarse al conector de conexión a tierra.

Verifique con un electricista o técnico de servicio calificado si las instrucciones para conectar a tierra no le han quedado completamente claras, o si duda que el producto haya quedado conectado a tierra de manera apropiada. No modifique el enchufe que se proporciona. Si el enchufe no entra en la toma de corriente, pídale a un electricista calificado que instale la toma apropiada.

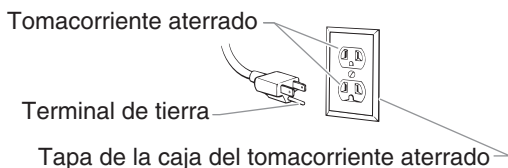

⚠️ PRECAUCION

Use solamente extensiones trifilares que tengan un enchufe de conexión a tierra de 3 hojas y un receptáculo de triple ranura que acepte el enchufe del producto. Asegúrese de que su extensión esté en buenas condiciones. Cuando use una extensión, asegúrese de usar una que sea lo suficientemente resistente como para soportar la corriente que descargue su producto. Un cable de un tamaño menor causará una caída de voltaje en la línea que dará como resultado una pérdida de energía y un sobrecalentamiento. Se recomienda usar un cable de calibre 12. Si se utiliza un cable de extensión en el exterior, tiene que estar marcado con el sufijo W-A después de la designación del tipo de cable. Por ejemplo, SJTW-A para indicar que el cable es apropiado para uso en exteriores.

Seguridad con los motores de gasolina

⚠️ ADVERTENCIA

El escape del motor de esta unidad contiene químicos que el Estado de California ha determinado causan cáncer, defectos de nacimiento u otros daños al sistema reproductor.

1. Los motores Honda están diseñados para proporcionar un servicio seguro y fiable, si se utilizan de acuerdo a las instrucciones. Lea y entienda las instrucciones del Manual del Propietario de Honda antes de utilizar el motor. De lo contrario, podría causar lesiones personales o daño al equipo.
2. Para evitar peligros de incendio y para proporcionar una ventilación adecuada, mantenga el motor por lo menos a 1 metro de los edificios y de otro equipo durante su uso. No coloque objetos inflamables cerca del motor.
3. Mantenga a los niños y las mascotas alejados de la zona de trabajo, pues existe la posibilidad de quemaduras causadas por los componentes calientes del motor o lesiones causadas por cualquier equipo en el que se utilice el motor.
4. Sepa cómo apagar el motor rápidamente y comprenda el funcionamiento de todos los controles. Nunca permita a nadie operar el motor sin las instrucciones apropiadas.
5. La gasolina es extremadamente inflamable y es explosiva bajo ciertas condiciones.
6. Llene el tanque de combustible en un lugar bien ventilado y con el motor apagado. No fume ni permita que haya llamas ni chispas en la zona de llenado ni en donde se almacena el combustible.
7. No llene en exceso el tanque de combustible. Después de ponerle combustible, asegúrese de que la tapa del tanque esté cerrada completamente.
8. Tenga cuidado de no derramar el combustible. Los gases del combustible o el combustible derramado pueden encenderse. Si se derrama combustible, asegúrese de que la zona esté seca antes de encender el motor.
9. Nunca utilice el motor en un lugar encerrado o confinado. El escape contiene gas de monóxido de carbono venenoso; la exposición a este gas puede causar pérdida del conocimiento y puede conducir a la muerte.
10. El escape se calienta mucho durante su uso y permanece caliente durante un rato después de apagar el motor. Asegúrese de no tocar el escape cuando esté caliente. Para evitar quemaduras graves o peligros de incendio, deje que el motor se enfríe antes de transportarlo o guardarlo bajo techo.
11. Nunca envíe ni transporte la unidad con gasolina en el tanque.

⚠️ ADVERTENCIA

No utilice este equipo para rociar agua o ácido.

⚠️ PRECAUCION

No cargue el equipo por el asa del carrito durante la carga y descarga.

Parts Lists and Service Instructions

Main Assembly

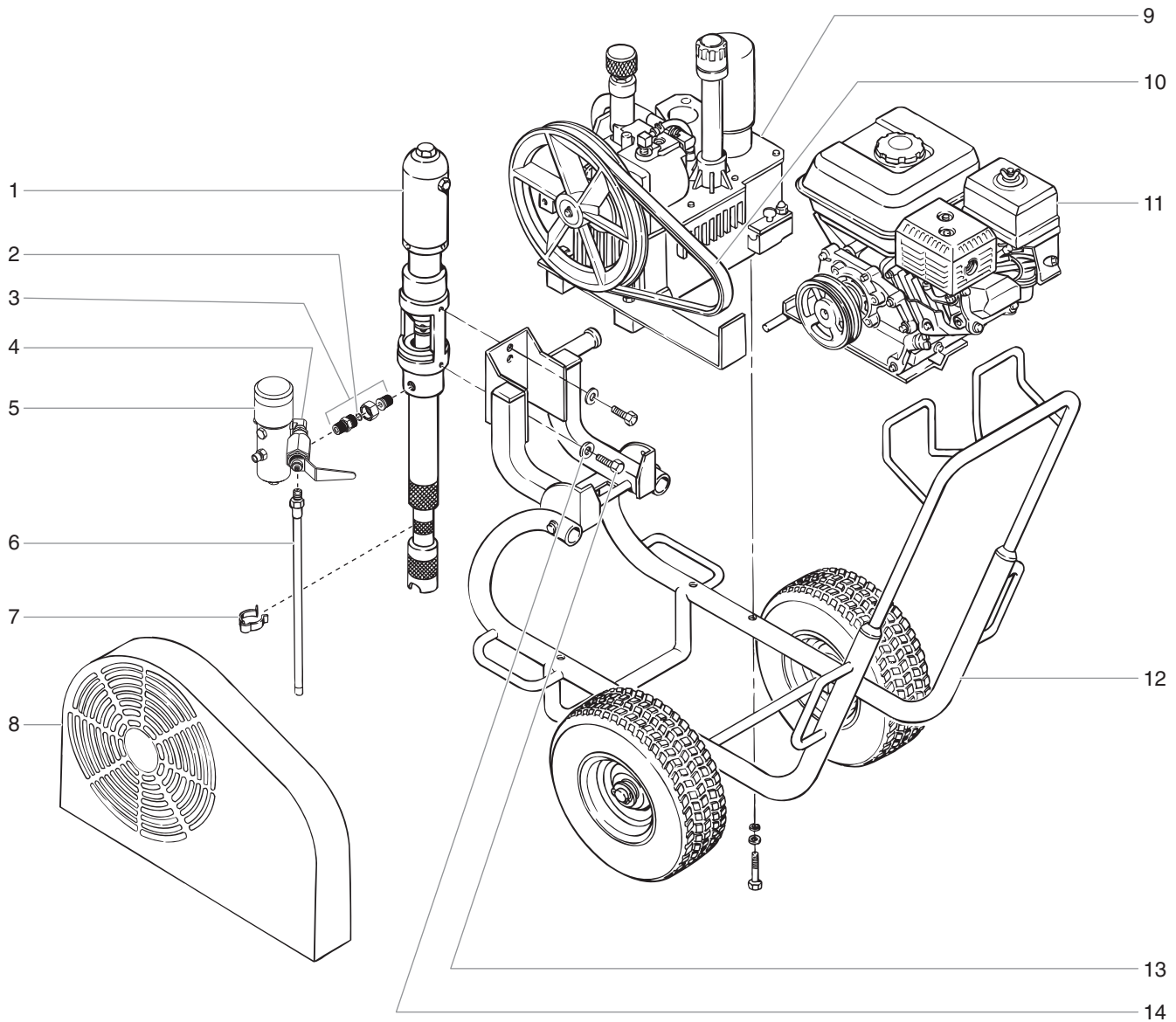

Item	Part #	Description	Quantity
1	451-135	Motor/pump assembly	1
2	703-136	O-ring	1
3	703-137	Swivel fitting assembly (includes item 2) ..	1
4	944-030	Bleed valve.....	1
5	451-136	Filter assembly	1
6	451-139	Bleed hose	1
7	730-334	Hose clamp	1
8	-----	Belt guard assembly.....	1
9	-----	Hydraulic system	1
10	449-181	Belt, "V" (gas model)	1

Item	Part #	Description	Quantity
11	506-275	Convertokit, 5.5 HP, Honda, gasoline (gas model)	1
12	451-070	Cart assembly	1
13	862-428	Screw	2
14	862-002	Washer	2
15	506-279	Convertokit, DC electric, 120V (electric model, includes belt, not shown) ..	1
16	506-251	Convertokit, 3 HP, electric, 230V (electric model, not shown)	1

Cart Assembly (P/N 451-070)

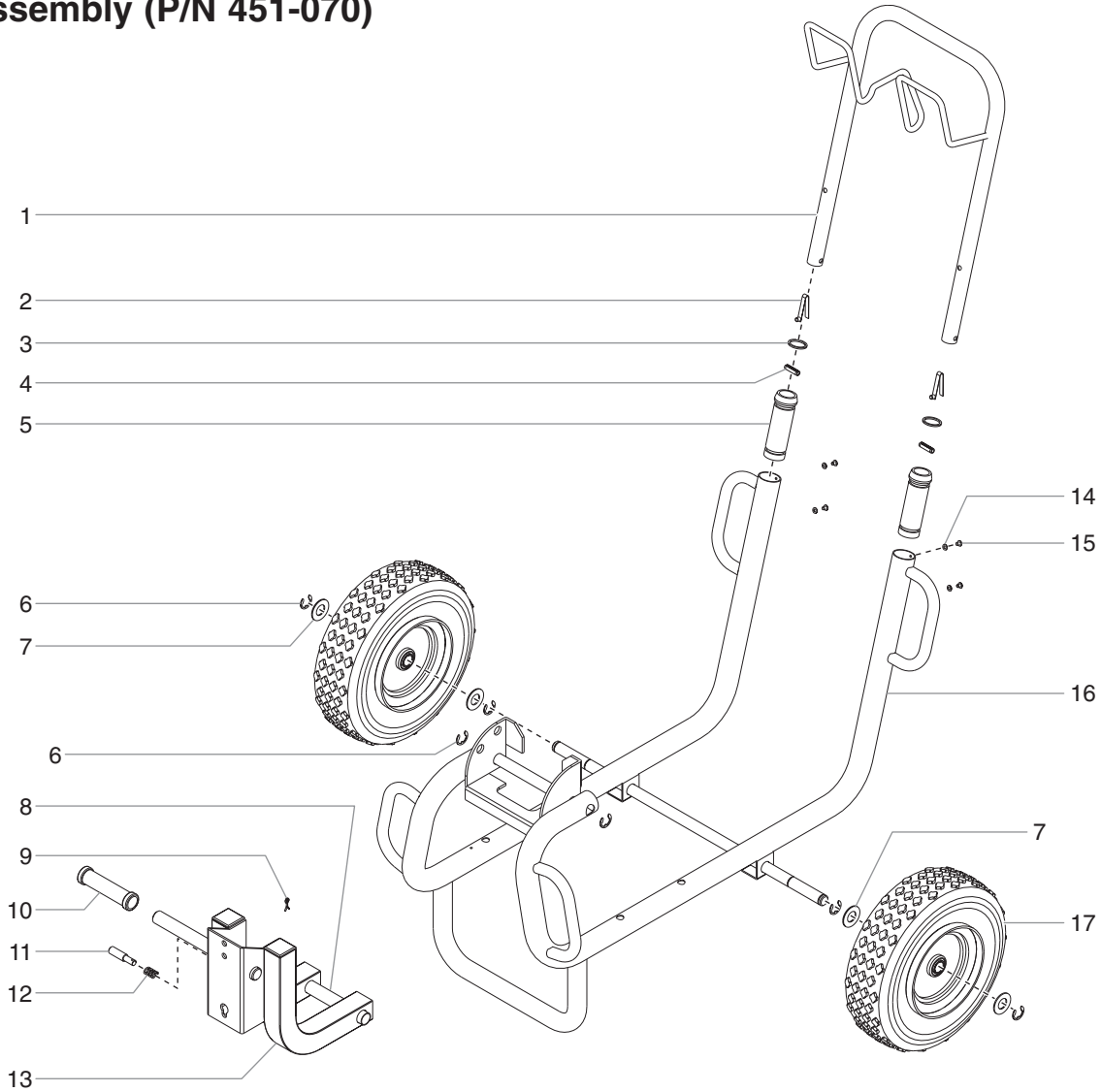

Item	Part #	Description	Quantity
1	590-502	Handle	1
2	590-507	Snap button	2
3	590-506	Handle washer.....	2
4	590-508	Roll pin.....	2
5	590-504	Handle sleeve.....	2
6	590-100	Retaining ring.....	6
7	870-004	Washer.....	4
8	451-064	Swing arm axle	1
9	759-034	Cotter pin	1
10	451-074	Grip	1

Item	Part #	Description	Quantity
11	451-113	Lock pin	1
12	451-112	Spring	1
13	451-059	Swing arm.....	1
14	856-002	Lock washer.....	4
15	856-921	Screw	4
16	451-053	Frame	1
17	670-109	Wheel.....	2
18	451-052	Plug (not shown).....	2
19	451-455	Cart handle spacer (not shown)	1

Belt Guard Assembly

Item	Part #	Description	Quantity
1	449-217	Belt guard, gas model.....	1
	449-216	Belt guard, 230V electric model	
2	858-636	Screw	2
3	858-002	Lockwasher.....	2
4	862-411	Nut	1
5	449-185	Belleville washer.....	1
6	862-001	Flat washer	1
7	449-187	Clip.....	1
8	449-198	Flat washer	1
9	449-166	Bolt.....	1
	313-2685	Label (not shown)	

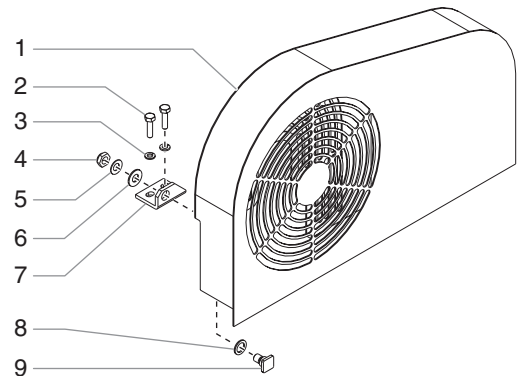

Hydraulic Motor

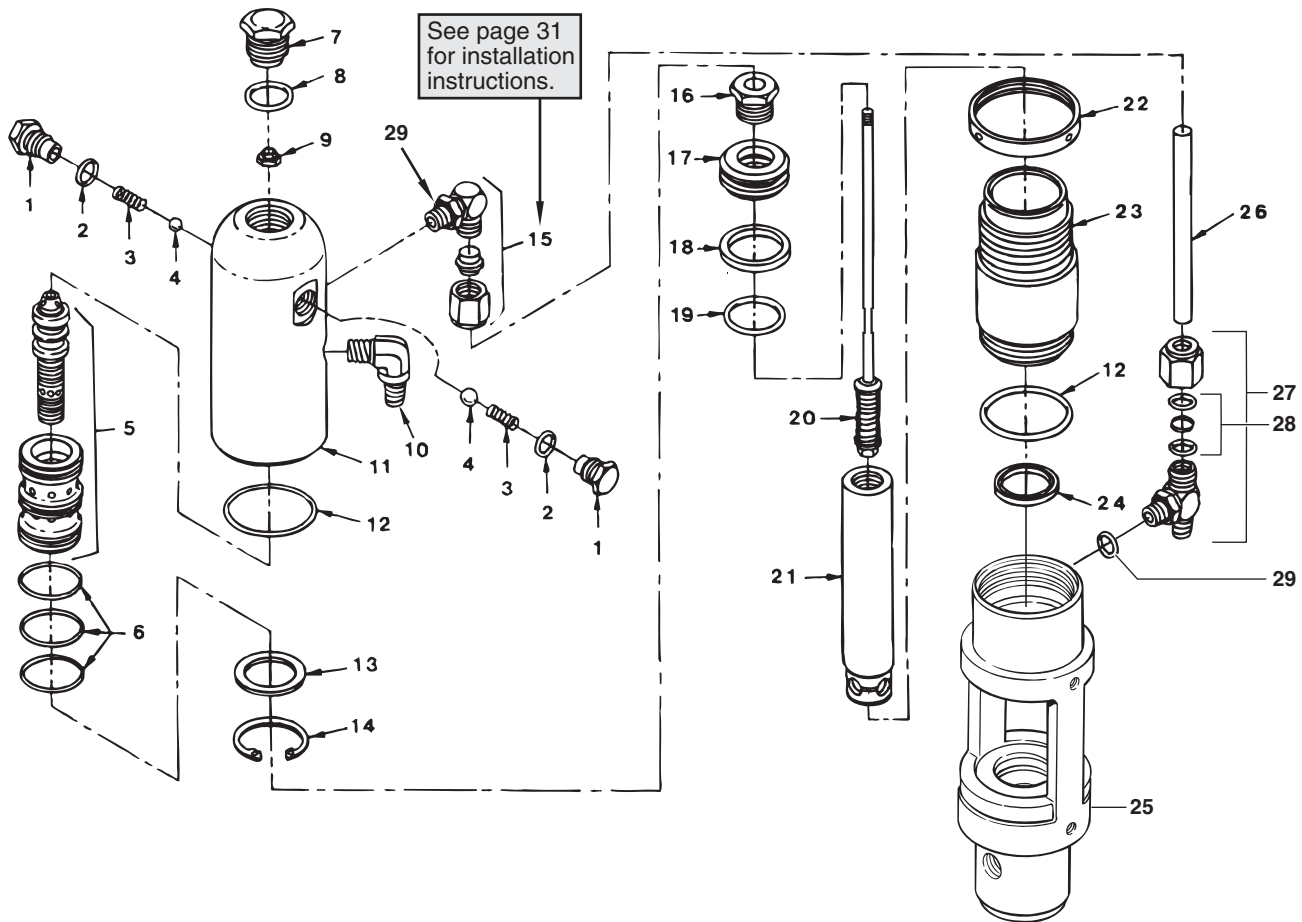

Item	Part #	Description	Quantity
1	235-018	Trip retainer	2
2	141-007	O-ring	2
3	325-005	Trip spring,	2
4	569-016	Ball, SS.....	2
5	441-908	Spool / sleeve set.....	1
6	441-152	O-ring	3
7	235-030	Cylinder head plug	1
8	441-217	O-ring	1
9	858-811	Flex lock nut.....	1
10	451-121	Elbow, 90°.....	1
11	235-112	Cylinder head	1
12	431-032	O-ring	2
13	431-053	Sleeve retainer	1
14	431-054	Retainer ring.....	1
15	192-000	Elbow.....	1
16	235-022	Piston retainer screw.....	1
17	235-014	Piston	1
18	235-027	Piston seal.....	1
19	235-026	O-ring	1
20	235-021	Valve rod assembly	1
21	235-948	Piston rod	1
22	235-001	Lock ring.....	1
23	235-007	Cylinder	1
24	235-028	Rod seal	1
25	235-129	Motor/pump block.....	1
26	235-029	Motor tube	1
27	235-125	Tee.....	1
28	431-019	O-ring kit.....	1
29	700-499	O-ring	2
	235-050	Motor service kit, minor (includes items 2-4, 6, 8, 9, 12, 18, 19, and 24)	

Servicing the Hydraulic Motor

Perform this procedure using the necessary parts from Motor Service Kit — Minor (P/N 235-050). If the hydraulic motor is operable, start the machine and jog the piston rod (21) into its top position.

NOTE: Servicing of the hydraulic motor should be carried out in a clean, dust free area only. Any dust or metallic particles left in the motor or entering it on reassembly may damage the critical parts and affect its service life and warranty. All parts should be inspected for absolute cleanliness.

Disassembling the Hydraulic Motor

1. Disconnect the pressure hose from the elbow (34 and 35 in Hydraulic System parts list) on the back of the hydraulic pump.
2. Remove the two mounting screws and two lock washers (13 and 14 in Main Assembly parts list) that attach the motor/pump assembly to the cart.
3. Place the motor/pump assembly in a vise, holding it securely by the motor/pump block (25).
4. Remove cylinder head plug (7).
5. Loosen lock ring (22) with a spanner wrench and unthread tube retaining nut on tee (27). Loosen tube retaining nut on elbow (15). Slide the nut down. Push motor tube (26) into tee (27) far enough to clear elbow (15). Slowly unthread cylinder head (11) and lift it just high enough above the cylinder (23) to reach the valve rod assembly (20) with vise grip pliers.
6. The piston rod (21) should be near the top of its stroke for disassembly. It may be necessary to use a wood or nylon driver to push the piston rod up to its top position.

7. Grip the valve rod securely with vise grip pliers and then remove the FlexLoc nut (9) from the top of the valve rod assembly (20). Be careful that spool (5) does not fall. The cylinder head (11) can now be lifted off. Unthread the cylinder (23) from the motor/pump block (25). Note: An extra lock ring (22) can be used to jam the two lock rings together on the cylinder and a pipe wrench can be used to unthread the cylinder (23) from the motor/pump block (25).

8. To remove the connecting pin, slide the retaining ring down with a small screwdriver, and then push the connecting pin out.

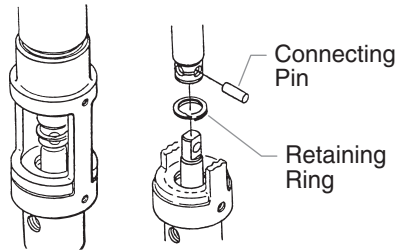

9. Remove the piston rod assembly from the motor/pump block (25).

10. Remove rod seal (24), being extremely careful not to scratch the seal groove in the motor/pump block (25).
11. Place the piston retainer screw (16) on the piston rod assembly in a vise. Slide a long bar through the hole at the base of the piston rod for leverage, and unthread the piston rod from the piston retainer screw.
12. Remove piston (17) and lift out valve rod assembly (20).
13. Remove piston seal (18) and o-ring (19).
14. Remove trip retainers (1), trip springs (3), and balls (4) from cylinder head (11). Remove o-rings (2) from trip retainers (1).
15. Remove retaining ring (14) and sleeve retainer (13). Gently tap spool/sleeve set (5) out of cylinder head (11) using a wood or nylon rod.
16. Inspect piston rod (21) and cylinder (23) for wear, scratches, and dents. Replace if damaged.
17. Inspect spool valve (5) for wear. Replace if necessary. spool valve should move smoothly and freely with no force by holding in a vertical position. If it does not, it can cause the motor to stall.

Reassembling the Hydraulic Motor

1. Separate spool/sleeve set (5). Place o-rings (6) onto sleeve. Lubricate o-rings with hydraulic oil. Gently push the sleeve into cylinder head (11) with the flatter side of the sleeve facing out. Use a nylon rod to tap sleeve down until it reaches its full depth. Do not use any other type of tool that might damage or leave particles or residue on the sleeve. Install the spool through the top of the cylinder head, down into the sleeve.

CAUTION

Do not use Piston Lube pump packing lubricant. It is a solvent and will severely damage seals and O-Rings of the hydraulic motor.

2. Install o-rings (2) on trip retainers (1). Install trip retainer balls (4) followed by springs (3) which, when installed, will hold spool/sleeve set (5) in proper place for assembly.
3. Install sleeve retainer (13) followed by snap ring (14) into cylinder head (11), which will hold valve sleeve in place. Install o-ring (12) in the o-ring groove of the cylinder head.
4. Replace lower seal (24) in motor/pump block (25). Be sure the open portion of the seal is facing upward (V). This seal requires no special tool.
5. Place piston rod (21) in vise. Inspect valve rod assembly (20) for any damage. Make sure the lock nut at the bottom of the valve rod assembly (20) is secure. DO NOT remove. Then, place into piston rod (21) as illustrated. Install o-ring (19), lubricating it well and replacing piston (17) onto piston rod (21). Put one drop of blue Loctite on the piston retainer screw (16). Tighten piston retainer screw until piston is locked into place. Check valve rod assembly (20) for normal spring action at this time.

6. Install piston seal (18) with lips facing downward. Carefully install o-ring (19). Expand the ring and stretch it sufficiently for installation.
7. With motor/pump block (25) still in vise, install lower seal (24) by pushing it towards its groove with a properly sized blunt rod. Then complete installation with the fingers. No tool is necessary. Do not twist the seal.
8. Pre-lubricate the piston and valve rod assembly with Coolflo™ hydraulic fluid (P/N 430-361). Install piston rod (21) into motor/pump block (25) with a gently pushing and rotating motion to work the piston rod in through the seal (24).

NOTE: Inspect the bottom of piston rod (21) for nicks or sharp areas that could damage the piston seal during installation through the motor/pump block (25).

9. Replace the connecting rod pin and retainer ring.
10. Install o-ring (12) on cylinder wall. Lubricate ring and inner wall. With the piston rod held firmly, the cylinder should be gently driven over the piston seal with a rubber mallet. Tightly thread the cylinder into motor/pump block (25).
11. Raise piston rod (21) to top position and thread lock ring (22) all the way up on upper threads of cylinder (23).
12. Pull valve rod assembly (20) up as far as it will travel and grasp it with vise grip pliers. Then install cylinder head (11), already assembled, over valve rod until the top threads of the valve rod pass through the top of the spool/sleeve set (5). The valve rod threads must be clean and free of oil. Place one drop of blue Loctite on threads of flex lock nut (9) and thread nut onto valve rod to full tight position (do not over-tighten) while holding valve rod below with vise grip pliers.
13. Thread cylinder head (11) down onto the cylinder (23) and then back off just enough to reassemble hydraulic fittings and motor tube (26). Tighten lock ring with spanner wrench to hold cylinder head in position.
14. The tee assembly (27) and the elbow (15) use an o-ring (28) to seal on the outer diameter (O.D.) of the motor tube (26). The O.D. of the motor tube should be free of scratches or sharp edges. The lock nuts on these fittings first should be hand tightened, then wrench tightened another half turn.
15. Install o-ring (8) onto cylinder head plug (7). Tighten.

Hydraulic Motor Cut-Away

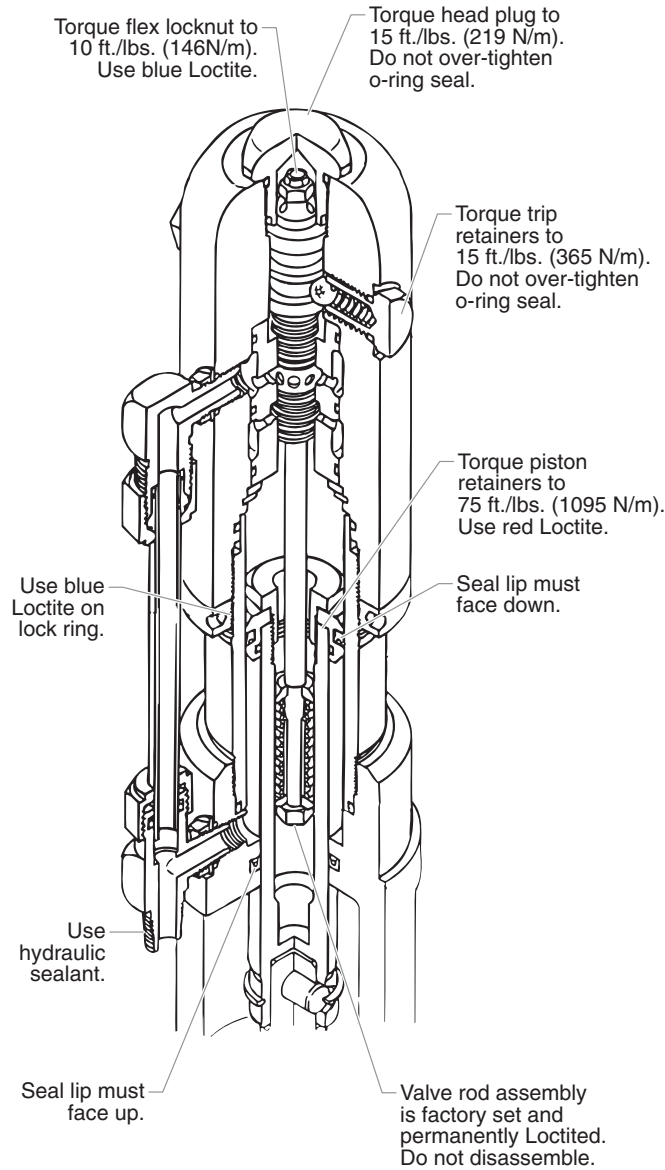

Fluid Section

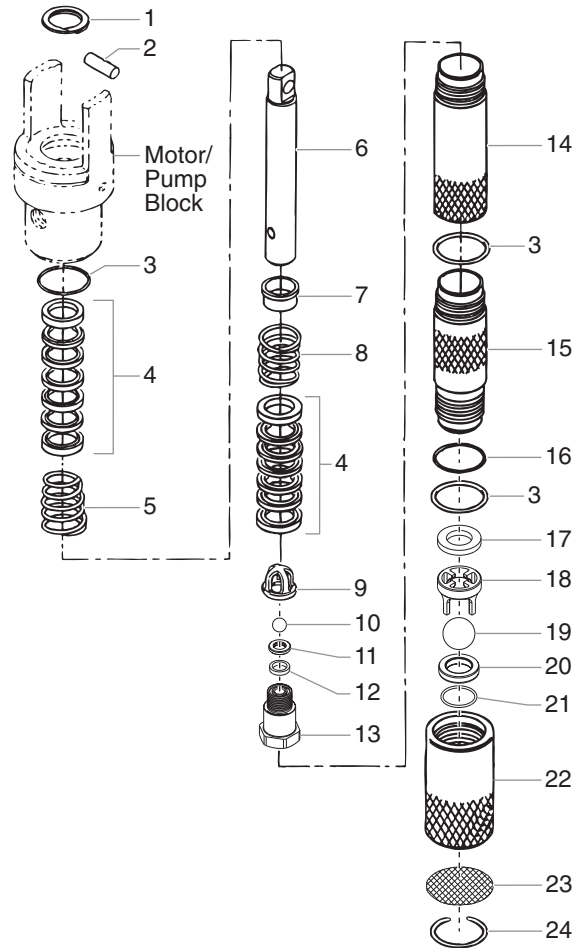

Item	Part #	Description	Quantity
1	143-019	Retaining ring	1
2	143-120	Connecting pin	1
3	145-031	O-ring, Teflon	3
4	138-153	Packing set, leather/UHMWPE/steel	2
5	142-004	Upper packing spring	1
6	451-031	Displacement rod	1
7	138-001	Spring retainer	1
8	142-003	Lower packing spring	1
9	451-085	Outlet valve cage	1
10	138-225	Outlet valve ball	1
11	236-012	Outlet valve seat	1
12	236-032	Seal washer	1
13	236-031	Outlet valve housing	1
14	451-032	Cylinder spacer	1
15	143-832	Pump cylinder	1
16	140-009	O-ring	1
17	236-030	Wave washer	1
18	236-141	Foot valve cage	1
19	178-700	Foot valve ball	1
20	143-026	Foot valve seat	1
21	143-025	Seat o-ring	1
22	451-132	Foot valve housing	1
23	451-018	Inlet screen	1
24	431-054	Snap ring	1
	143-501	Fluid section service kit, major (includes items 6, 15, and fluid section service kit, minor P/N 144-051)	
	144-051	Fluid section service kit, minor (includes items 1, 3, 4, 10, 12, 16, 19, 21, and Loctite P/N 426-051)	
	236-010	Foot valve assembly (includes items 18-21)	
	236-050	Outlet valve assembly (includes items 9-13)	

Servicing the Fluid Section

CAUTION

Use of non-Speeflo service parts may void warranty. Ask for original parts made by Speeflo for best services. This pump should receive a routine servicing after approximately 1,000 hours of use. Earlier servicing is required if there is excessive leakage from the top packing or if pump strokes become faster on one stroke or the other. The use of Speeflo Piston Lube (P/N 314-480) is recommended as an upper packing lubricant. Do not substitute oil, water, or solvent for an upper packing lubricant.

Disassembling the Fluid Section

1. Remove the foot valve housing (22), pump cylinder (15), and cylinder spacer (14) with a strap wrench.
2. Slide the retaining ring (1) up with a small screwdriver, then push the connecting pin (2) out.
3. Pull the displacement rod (6) through the lower cavity of the motor/pump block.
4. Remove the Teflon o-ring (3), upper packing spring (5), and upper packing set (4) from the motor/pump block.
5. Hold the displacement rod (6) in a vise by the flats at the top of the displacement rod and remove the outlet valve housing (13) with a wrench while holding the displacement rod horizontal with a wooden support, if necessary. Remove the seal washer (12), outlet valve seat (11), outlet valve ball (10), outlet valve cage (9), lower packing set (4), lower packing spring (8), and spring retainer (7).
6. Using a 1/2" extension bar attached to a 1/2" drive ratchet, insert the end of the extension bar into the square opening of the foot valve cage (18) inside the foot valve housing (22). Unscrew and remove the foot valve cage along with the wave washer (17) from the foot valve housing.
7. Remove the Teflon o-ring (3), foot valve ball (19), foot valve seat (20), and seat o-ring (21) from the foot valve housing (22).
8. Remove the o-ring (16) from the pump cylinder (15).

Reassembling the Fluid Section

NOTE: Use Teflon tape on all threaded pipe connections.

1. Place a new seat o-ring (21) into the groove in the bottom of the foot valve housing (22).
2. Inspect the foot valve seat (20) for wear. If one side is worn, flip the seat to the unused side. If both sides are worn, install a new seat. Place the new or flipped seat (worn side down) into the bore at the bottom of the foot valve housing (22).
3. Place a new foot valve ball (19) onto the foot valve seat (20). Using a 1/2" extension bar attached to a 1/2" drive ratchet, insert the end of the extension bar into the square opening of the foot valve cage (18) and screw the cage into the foot valve housing (22). Torque the cage to 300 in./lbs. (25 ft./lbs.).
4. Place the wave washer (17) on top of the foot valve cage (18).
5. Insert a new Teflon o-ring (3) into the groove of the foot valve housing (22). Lubricate the o-ring using oil or grease.
6. After soaking the leather packings in oil (preferably linseed oil), reassemble the lower packing set (4). Place the set onto the outlet valve housing (13) with the peak of the "V" packings pointing down toward the hex on the outlet valve housing.
7. Inspect the outlet valve seat (11) for wear. If one side is worn, flip the seat to the unused side. If both sides are worn, use a new seat. Insert the outlet valve cage (9), new outlet valve ball (10), new or flipped seat (worn side away from ball), and a new seal washer (12) into the displacement rod (6).

8. Clean the threads on the outlet valve housing (13) and coat the threads with blue Loctite #242. Make sure the Loctite is only on the threads.
9. Place the lower packing spring (8) onto the outlet valve housing (13) followed by the spring retainer (7).
10. Screw the displacement rod (6) and the outlet valve housing (13) together. Tighten in a vise to 900 in./lbs. (75 ft./lbs.).
11. Insert the Teflon o-ring (3) into the upper groove of the motor/pump block.
12. Insert the upper packing set (4) into the motor/pump block with the peak of the "V" packings pointing up toward the motor.

NOTE: The packings must be soaked in oil before installation.

13. Place the upper packing spring (5) into the motor/pump block with the small tapered end facing up toward the motor/pump block.
14. Insert the displacement rod (6) up through the upper packings in the motor/pump block.
15. Align the holes in the displacement rod (6) and the hydraulic piston rod and insert the connecting pin (2). Replace the retaining ring (1) over the connecting pin.
16. Thread the short threads of cylinder spacer (14) into the motor/pump block and tighten with a strap wrench.
17. Thread the short threads of the pump cylinder (15) into the cylinder spacer (14) and tighten with a strap wrench.
18. Place the o-ring (16) onto the top groove of the pump cylinder (15).
19. Thread the foot valve housing (22) onto the pump cylinder (15), tighten with a strap wrench.

NOTE: It is not necessary to over-tighten the foot valve. O-ring seals perform sealing function without excessive tightening. Full thread engagement is sufficient.

Fluid Section Cut-Away

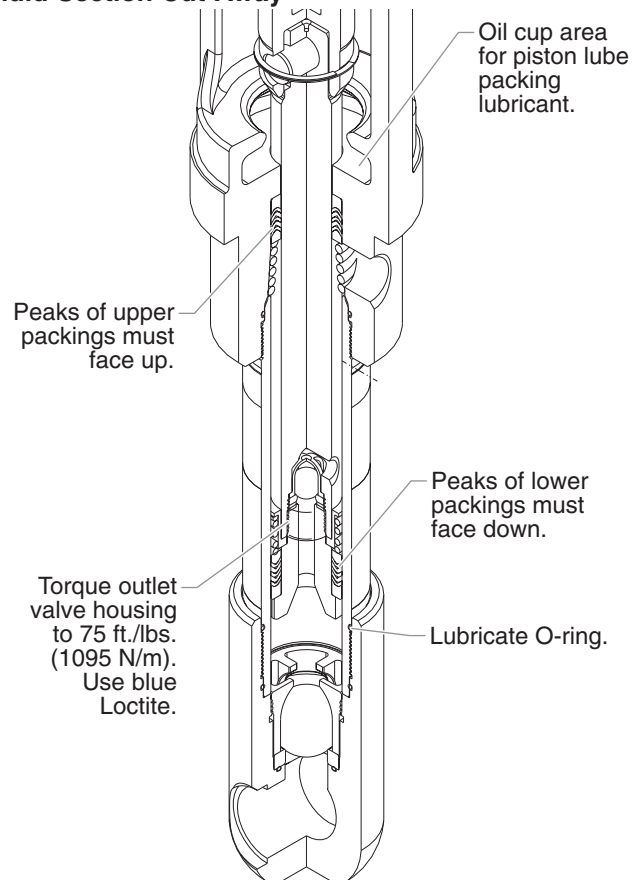

Hydraulic System

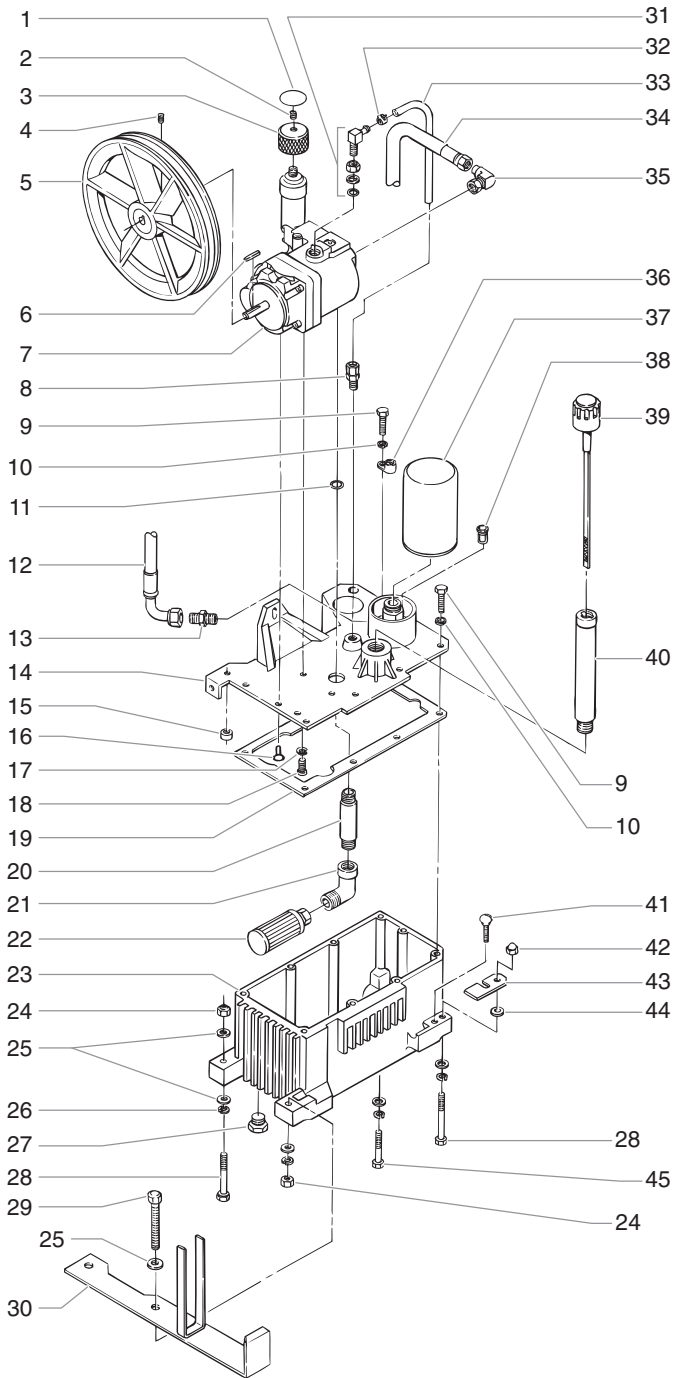

Item	Part #	Description	Quantity
1	313-755	Knob decal	1
2	862-414	Set screw.....	1
3	448-243	Pressure control knob	1
4	860-520	Set screw.....	1
5	449-195	Pulley/fan assembly	1
6	448-494	Key, pump (.156 x .156 x 1 ^{3/16})	1
7	449-752	Hydraulic pump	1
8	431-042	Tube connector	1
9	858-636	Screw, HH	8
10	858-002	Lock washer	10
11	325-031	O-ring	1
12	451-115	Return hose assembly	1
13	451-029	Fitting.....	1
14	449-616	Tank cover	1
15	858-609	Clinch nut	1
16	858-621	Socket screw	2
17	859-001	Washer	2
18	858-624	Screw	2
19	449-605	Tank gasket	1
20	112-208	Nipple	1
21	472-500	Elbow, street.....	1
22	448-208	Inlet screen.....	1
23	449-623	Hydraulic tank.....	1
24	862-411	Flex lock nut.....	2
25	862-001	Flat washer.....	6
26	862-002	Lock washer	4
27	449-212	Plug	1
28	862-493	Screw, HH	2
29	862-496	Tap bolt.....	1
30	449-282	Shield, gas model.....	1
	449-285	Shield, electric model	
31	192-228	Elbow.....	1
32	449-126	Hose clamp	1
33	420-250	Tubing, Teflon.....	1
34	451-114	Pressure hose assembly	1
35	192-051	Elbow.....	1
36	101-205	Ground lug.....	1
37	451-220	Hydraulic filter.....	1
38	449-609	Hydraulic by-pass.....	1
39	449-626	Hydraulic fluid cap/dipstick	1
40	449-614	Tube assembly	1
41	862-438	Thumb screw	1
42	862-402	Acorn nut	1
43	449-107	Mounting plate retainer	1
44	449-135	Spacer	1
45	862-480	Screw, HH	1
46	451-121	Elbow (not shown).....	1
47	941-555	Ball valve (not shown)	1

Torque and Sealant Guide

Item	Description
4	Use blue Loctite on threads
4	Torque to 10 ft./lbs. (13.5 N/m)
8	Use hydraulic sealant
9	Torque to 20 FT/LBS (28 N/m)
13	Use hydraulic sealant
16	Use blue Loctite on threads
16	Torque to 8 FT/LBS (11 N/m)
18	Torque to 8 FT/LBS (11 N/m)
20	Use hydraulic sealant
21	Use hydraulic sealant
22	Use hydraulic sealant
28	Torque to 15 FT/LBS (20,5 N/m)
29	Torque to 15 FT/LBS (20,5 N/m)
45	Torque to 15 FT/LBS (20,5 N/m)

Gas Convertokit (P/N 506-275)

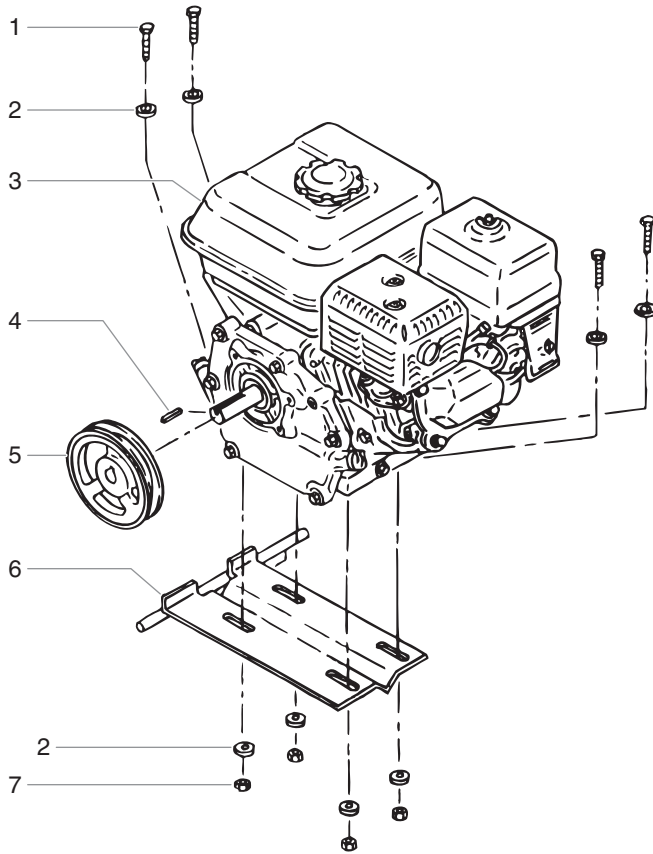

Item	Part #	Description	Quantity
1	860-552	Screw	4
2	860-004	Flat washer	8
3	980-331	Engine, gas 5.5 HP	1
4	980-307	Key	1
5	448-910	Pulley	1
6	449-219	Mounting plate, gas engine	1
7	860-502	Stop nut	4
8	449-181	Belt, "V" (not shown, not part of assembly)	

DC — Electric Convertokit (P/N 506-279)

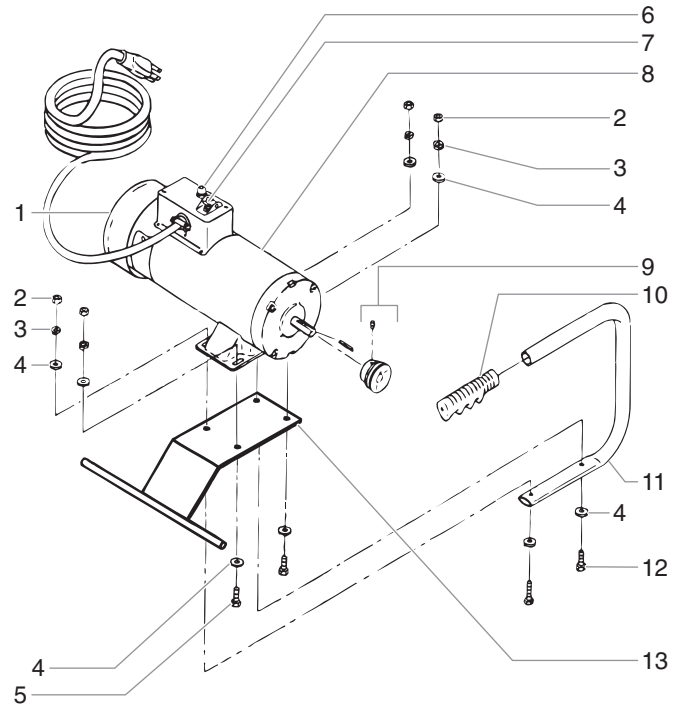

Item	Part #	Description	Quantity
1	506-259	Cover	1
2	860-501	Nut stop	4
3	860-002	Lock washer	4
4	860-004	Flat washer	8
5	860-535	Screw	2
6	978-040	Circuit breaker reset	1
7	506-260	ON/OFF switch	1
8	978-350	Motor, DC-Electric, 2 HP, 50 / 60 Hz, 115 V	1
9	977-228	Pulley	1
10	590-068	Handle grip	1
11	335-017	Handle	1
12	860-552	Screw	2
13	459-018	Mount plate	1
14	506-255	Rectifier (not shown)	1
15	506-258	Fan (not shown)	1
16	449-181	Belt, "V" (not shown)	1

Electric Convertokit, 230V (P/N 506-251)

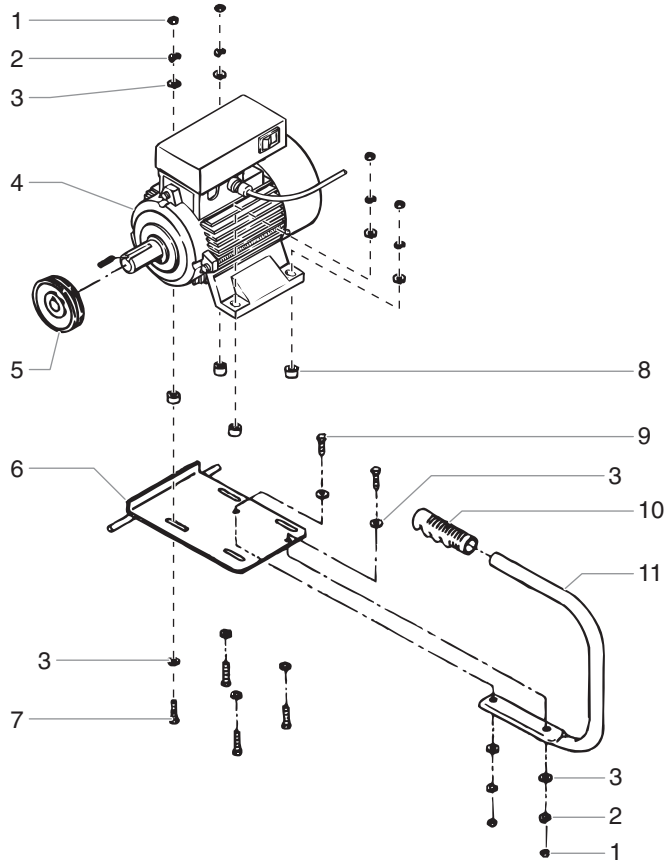

Item	Part #	Description	Quantity
1	860-501	Stop nut.....	6
2	860-002	Lock washer.....	6
3	860-004	Flat washer.....	12
4	978-365	Motor, electric, 3 HP, 50 Hz, 230 V.....	1
5	449-152	Pulley.....	1
6	449-121	Mounting plate, elec. motor, 3 HP.....	1
7	860-552	Screw, HH.....	4
8	590-411	Spacer.....	4
9	860-544	Screw, HH.....	2
10	590-068	Handle grip.....	1
11	335-016	Handle.....	1
12	449-181	Belt, "V" (not shown, not part of assembly)	

Bleed Valve Assembly (P/N 944-030)

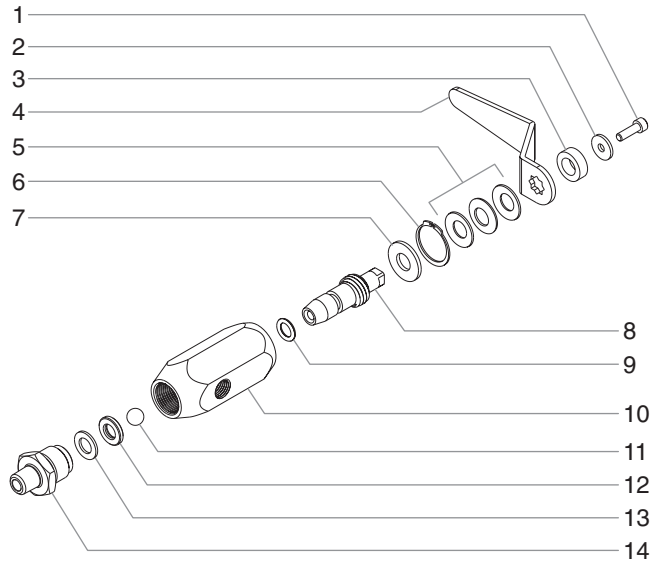

Item	Part #	Description	Quantity
1	944-047	Hex screw.....	1
2	944-029	Flat washer.....	1
3	944-046	Spacer.....	1
4	944-034	Valve handle.....	1
5	944-035	Spring washer.....	3
6	944-036	Retaining ring.....	1
7	944-029	Valve washer.....	1
8	944-011	Valve stem.....	1
9	944-038	Stem o-ring.....	1
10	944-031	Valve housing.....	1
11	944-039	Ball.....	1
12	944-043	Valve seat.....	1
13	944-044	Valve seal.....	1
14	944-013	Valve seat retainer.....	1

Filter Assembly (P/N 451-136)

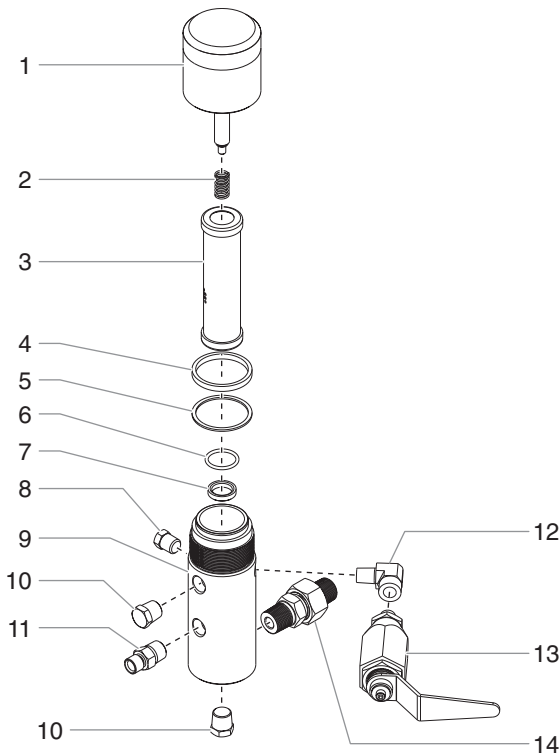

Item	Part #	Description	Quantity
1	930-937	Filter cap assembly	1
2	930-020	Spring	1
3	930-005	Filter element, 5 M, w/ball	1
	930-006	Filter element, 50 M, w/ball	
	930-007	Filter element, 100 M, w/ball	
4	920-006	Gasket, Teflon (thick)	1
5	920-070	Gasket, Teflon (thin)	1
6	891-193	O-ring, Teflon	1
7	180-909	Seat, tungsten carbide	1
8	227-027	Pipe plug	1
9	930-920	Filter body	1
10	227-033	Pipe plug	2
11	808-550	Hex fitting, 3/8"	1
12	810-555	Elbow, 90°	1
13	944-030	Bleed valve	1
14	703-137	Swivel fitting assembly	1
	930-050	Filter service kit (includes items 2, 4, 5, and 6)	

Specifications

Maximum Working Pressure	5000 psi (34.5 MPa)
Filter Area	18 In ² (116 cm ²)
Outlet Ports	(1) 1/4" NPT(F) for bleed valve (1) 3/8" NPT(F) with 3/8 NPSM(M) hose connection (1) 3/8" NPT(F) plugged for additional gun hookup
Wetted Parts	Carbon steel with electroless nickel plating, stainless steel, tungsten carbide, Teflon

Heavy Duty Outlet Assembly (optional, P/N 448-615)

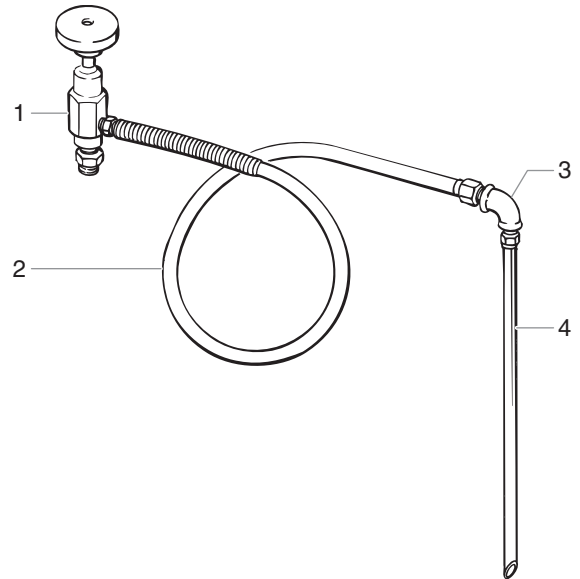

Item	Part #	Description	Quantity
1	945-600	Heavy duty bleed valve assembly	1
2	538-031	Hose assembly	1
3	201-555	Elbow	1
4	103-317	Tube	1
5	103-106	Heavy duty bleed line assembly (includes items 2-4)	1

Heavy Duty Bleed Valve Assembly (optional, P/N 945-600)

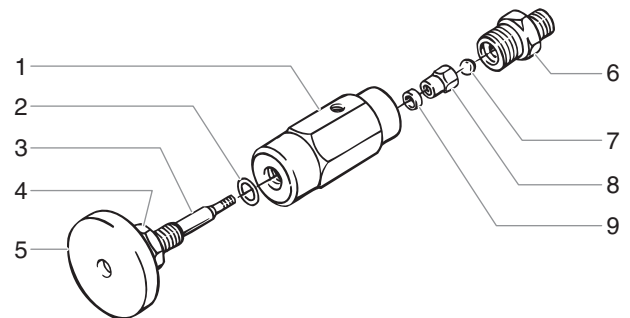

Item	Part #	Description	Quantity
1	945-022	Valve body	1
2	891-073	O-ring, Teflon	1
3	945-023	Valve stem	1
4	970-011	Lock nut	1
5	945-005	Knob	1
6	945-906	Valve seat	1
7	138-226	Ball, T.C.	1
8	945-026	Valve stem stop	1
9	891-183	O-ring, Teflon	1

Gun Manifold Assemblies (Optional)

Single Gun Add-On Manifold Assemblies

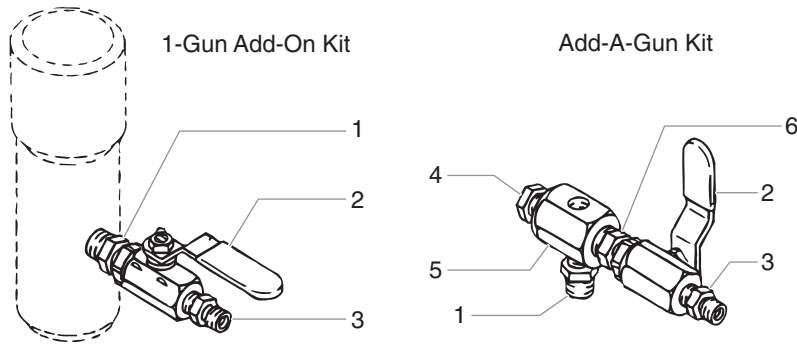

Item	Part #	Description	975-111 1 Gun Add-On 1/4"	975-311 1 Gun Add-On 3/8"	975-200 Add-A-Gun Kit 1/4"	975-300 Add-A-Gun kit 3/8"
1	814-002	Nipple, Hex	1		1	
	814-004	Nipple, Hex		1		1
2	940-553	Valve, Ball	1		1	
	941-555	Valve, Ball		1		1
3	227-006	Nipple, Hex	1		1	
	808-555	Nipple, Hex		1		1
4	227-033	Plug, Pipe			1	1
5	970-100	Block, Manifold			1	1
6	814-004	Nipple, Hex			1	1

Multiple Gun Add-On Manifold Assemblies

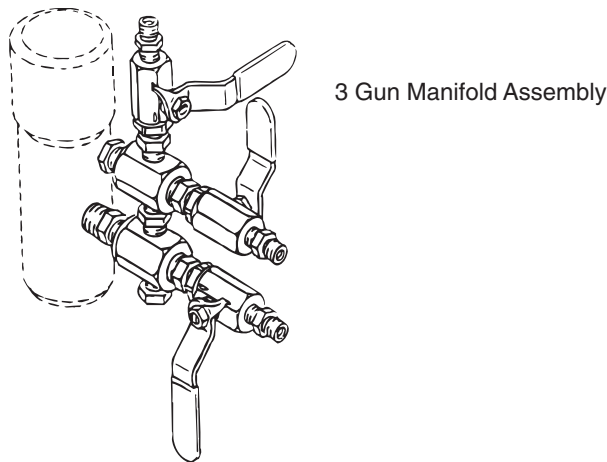

Part #	Description	975-212 2 Gun 1/4"	975-213 3 Gun 1/4"	975-214 4 Gun 1/4"	975-312 2-GUN 3/8"	975-313 3-GUN 3/8"	975-314 4-GUN 3/8"
975-111	1 Gun Add-On, 1/4"	1	1	1			
975-311	1 Gun Add-On, 3/8"				1	1	1
975-200	Add-A-Gun Kit, 1/4"	1	2	3			
975-300	Add-A-Gun Kit, 3/8"				1	2	3

SAE O-Ring Fitting Installation

Steps 1 & 2:

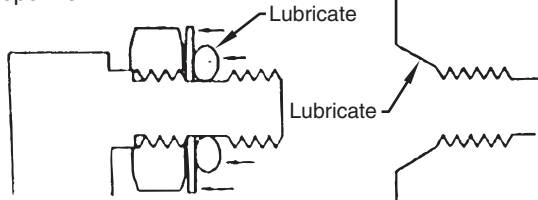

Step 3:

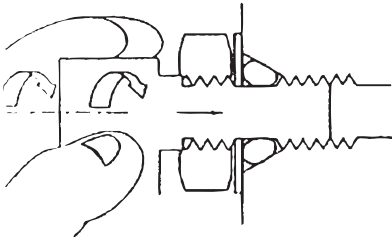

1. Pull washer and o-ring back as far as possible.
2. Lubricate o-ring and entrance port.
3. Screw fitting in until washer pushes o-ring into entrance and sits flat against port. (Do not tighten! - only do this step hand tight to compress o-ring into port!)

Step 4:

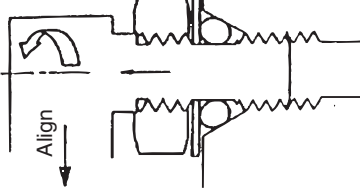

4. Back fitting out no more than one complete turn to align as required.

Step 5:

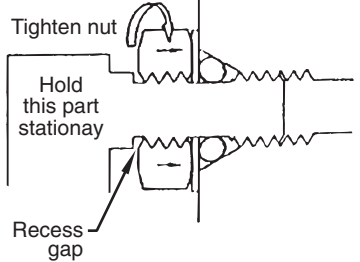

5. Torque nut wrench tight holding backup on fitting. This should expose a recess gap behind the nut which can act as an indicator that the fitting is assembled correctly. (This is a feature for a specific version of this fitting only - which screws into the cylinder head. Other fittings, as the ones which attach to the hydraulic pump, assemble the same but may not have the indicator.)

Cautions:

Avoid screwing fitting in too far.

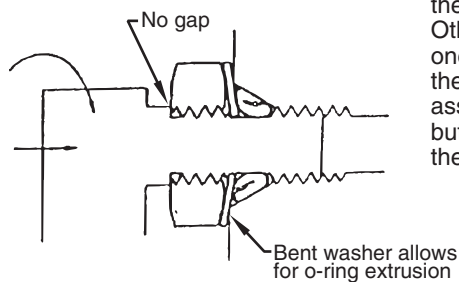

Avoid leaving fitting too far out.

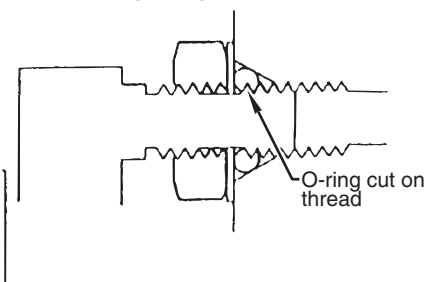

Accessories and Service Kits

These items may be purchased separately from your local Speeflo distributor.

Part #	Description
103-830	5 Gal. Siphon Hose Assembly w/Rock Catcher 1" x 4.5'
103-808	55 Gal. Siphon Hose Assembly w/Rock Catcher 1" x 6.5'
103-627	Rock Catcher
930-004	Paint Filter Element, 0 Mesh (for mastics)
930-005	Paint Filter Element, 5 Mesh (for multicolors and heavy materials)
930-006	Paint Filter Element, 50 Mesh (for latex and normal architectural materials)
930-007	Paint Filter Elements, 100 Mesh (for stains, lacquers and fine materials)
550-100	S-5 Gun w/Tip
550-110	S-5 Gun, Tip, and 1/4" Hose Kit
101-208	Grounding Clamp
101-212	Grounding Wire, 12 Gauge x 25'
314-480	Piston Lube, 8 oz.
314-482	Liquid Shield Plus, 1 quart
430-362	Coolflo™ Hydraulic Fluid, 1 quart
430-361	Coolflo™ Hydraulic Fluid, 1 gallon
975-212	2-Gun Manifold with Ball Valves, 1/4"
975-213	3-Gun Manifold with Ball Valves, 1/4"
975-312	2-Gun Manifold with Ball Valves, 3/8"
975-313	3-Gun Manifold with Ball Valves, 3/8"
808-550	3/8" NPS(M) x 3" hex fitting

Airless Tip Selection

Tips are selected by the orifice size and fan width. The proper selection is determined by the fan width required for a specific job and by the orifice size that will supply the desired amount of fluid and accomplish proper atomization.

For light viscosity fluids, smaller orifice tips generally are desired. For heavier viscosity materials, larger orifice tips are preferred. Please refer to the chart below.

NOTE: Do not exceed the pump's recommended tip size.

The following chart indicates the most common sizes and the appropriate materials to be sprayed.

Tip Size	Spray Material	Filter Type
.011 - .013	Laquers and stains	100 mesh filter
.015 - .019	Oil and latex	50 mesh filter
.021 - .026	Heavy bodied latex and blockfillers	5 mesh filter

Fan widths measuring 8" to 12" (20 to 30 cm) are most preferred because they offer more control while spraying and are less likely to plug.

Limited Warranty

Titan Tool, Inc., ("Titan") warrants that at the time of delivery to the original purchaser for use ("End User"), the equipment covered by this warranty is free from defects in material and workmanship. With the exception of any special, limited, or extended warranty published by Titan, Titan's obligation under this warranty is limited to replacing or repairing without charge those parts which, to Titan's reasonable satisfaction, are shown to be defective within twelve (12) months after sale to the End User. This warranty applies only when the unit is installed and operated in accordance with the recommendations and instructions of Titan.

This warranty does not apply in the case of damage or wear caused by abrasion, corrosion or misuse, negligence, accident, faulty installation, substitution of non-Titan component parts, or tampering with the unit in a manner to impair normal operation.

Defective parts are to be returned to an authorized Titan sales/service outlet. All transportation charges, including return to the factory, if necessary, are to be borne and prepaid by the End User. Repaired or replaced equipment will be returned to the End User transportation prepaid.

THERE IS NO OTHER EXPRESS WARRANTY. TITAN HEREBY DISCLAIMS ANY AND ALL IMPLIED WARRANTIES INCLUDING, BUT NOT LIMITED TO, THOSE OF MERCHANTABILITY AND FITNESS FOR A PARTICULAR PURPOSE, TO THE EXTENT PERMITTED BY LAW. THE DURATION OF ANY IMPLIED WARRANTIES WHICH CANNOT BE DISCLAIMED IS LIMITED TO THE TIME PERIOD SPECIFIED IN THE EXPRESS WARRANTY. IN NO CASE SHALL TITAN LIABILITY EXCEED THE AMOUNT OF THE PURCHASE PRICE. LIABILITY FOR CONSEQUENTIAL, INCIDENTAL OR SPECIAL DAMAGES UNDER ANY AND ALL WARRANTIES IS EXCLUDED TO THE EXTENT PERMITTED BY LAW.

TITAN MAKES NO WARRANTY AND DISCLAIMS ALL IMPLIED WARRANTIES OF MERCHANTABILITY AND FITNESS FOR A PARTICULAR PURPOSE WITH RESPECT TO ACCESSORIES, EQUIPMENT, MATERIALS OR COMPONENTS SOLD BUT NOT MANUFACTURED BY TITAN. THOSE ITEMS SOLD, BUT NOT MANUFACTURED BY TITAN (SUCH AS GAS ENGINES, SWITCHES, HOSES, ETC.) ARE SUBJECT TO THE WARRANTY, IF ANY, OF THEIR MANUFACTURER. TITAN WILL PROVIDE THE PURCHASER WITH REASONABLE ASSISTANCE IN MAKING ANY CLAIM FOR BREACH OF THESE WARRANTIES.

Patents

These products are covered by one or more of the following U.S. patents:

5,947,381

5,749,528

5,660,332

5,425,506

4,611,758

4,508,268

Material Safety Data Sheets (MSDS) are available on Titan's website or by calling Customer Service.



United States Sales & Service
1-800-526-5362
Fax 1-800-528-4826

Canadian Branch
1-800-565-8665
Fax 1-905-856-8496

International
1-201-337-1240
Fax 1-201-405-7449



107 Bauer Drive
Oakland, NJ 07436

200 Trowers Road, Unit 7B
Woodbridge, Ontario L4L 5Z8

107 Bauer Drive
Oakland, NJ 07436 USA

www.titantool.com

